

**BIRLA INSTITUTE OF TECHNOLOGY, MESRA, RANCHI  
(END SEMESTER EXAMINATION)**

CLASS: BTECH  
BRANCH: EEE

SEMESTER : VI  
SESSION : SP/2025

**SUBJECT: EE401 SWITCHGEAR AND PROTECTION**

TIME: 3 Hours

FULL MARKS: 50

**INSTRUCTIONS:**

1. The question paper contains 5 questions each of 10 marks and total 50 marks.
  2. Attempt all questions.
  3. The missing data, if any, may be assumed suitably.
  4. Before attempting the question paper, be sure that you have got the correct question paper.
  5. Tables/Data hand book/Graph paper etc. to be supplied to the candidates in the examination hall.
- 

- |  |     | CO | BL |
|--|-----|----|----|
| Q.1(a) i) Why does DC component come in closure of A.C. Circuit? ii) For a 220 kV, 60 Hz system, the reactance and capacitance up to the location of the circuit breaker is 3 ohms and 0.025 $\mu$ F, respectively. Calculate the following: (a) The frequency of transient oscillation (b) The maximum value of restriking voltage across the contacts of the circuit breaker (c) The maximum value of RRRV | [5] | 2  | 3  |
| Q.1(b) i) Discuss the properties of SF6 circuit breakers for high voltage applications. ii) What different parameters should be considered for deciding the rating of circuit breakers?  | [5] | 2  | 2  |
| Q.2(a) i) Discuss the working principle of induction disc relay. ii) What is static relay? Merits and demerits of static relays?   | [5] | 1  | 2  |
| Q.2(b) Draw a mho relay characteristic. Discuss the effect of arc resistance on mho relay reach. Discuss the performance of mho relay during power swing.  | [5] | 1  | 2  |
| Q.3(a) What is magnetizing inrush problem in a transformer? How can we avoid the tripping of differential relay during magnetizing inrush current?   | [5] | 3  | 2  |
| Q.3(b) A three-phase, 33 kV/66 kV, Y-D connected power transformer is protected by differential protection. The CTs on the HV side have a current ratio of 500/5. What must be the ratio of CTs on the LV side? How are the CTs on both sides of the transformer connected?  | [5] | 3  | 3  |

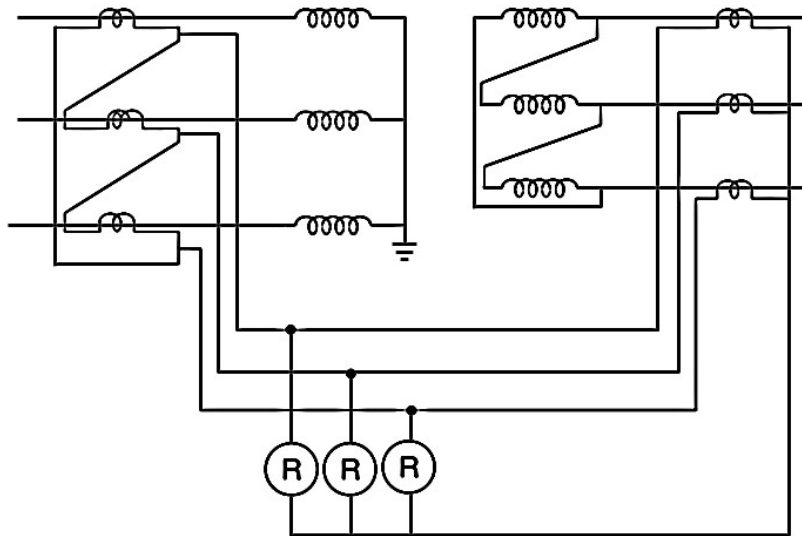

PTO

- Q.4(a) Two relays  $R_1$  and  $R_2$  are connected in two sections of a feeder as shown in the below figure. CTs are of ratio 1000/5 A. The plug setting of relays  $R_1$  is 150% and  $R_2$  is 120%. The operating time characteristics of the relays is same as given in the below table. The time multiplier setting of the relay  $R_1$  is 0.3. The time grading scheme has a discriminative time margin of 0.4 s between the relays. A three-phase short circuit at F results in a fault current of 6000 A. Find the actual operating times of  $R_1$  and  $R_2$ . What is the time multiplier setting (TMS) of  $R_2$ . [5] 4 3

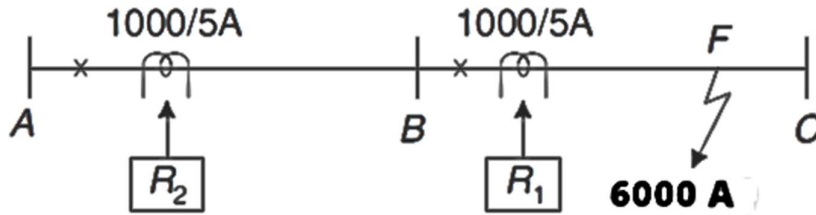

Table						
PSM	2	4	5	8	10	20
Operating time in seconds	10	5	4	3	2.8	2.4

- Q.4(b) Schematic diagram and explanation for single line to ground coupling a carrier and trapping it into desired line section for a carrier-aided distance protection. What type of communication is favored for carrier-aided distance protection, and what are the reasons for this preference? [5] 4 2
- Q.5(a) i) Discuss the problem and solution for the unbalanced supply voltage for an induction motor. ii) Discuss briefly the problem and solution for the lower supply voltage for an induction motor. [5] 5 2
- Q.5(b) i) Draw and explain the phase and ground faults protection of stator of generator using percentage differential protection. ii) Explain the problem and solution for loss of excitation of generator. [5] 5 2