

**BIRLA INSTITUTE OF TECHNOLOGY, MESRA, RANCHI
(END SEMESTER EXAMINATION)**

CLASS: BTECH
BRANCH: EEE

SEMESTER : II/ADD
SESSION : SP/2025

SUBJECT: EE24101 / EE101 BASICS OF ELECTRICAL ENGINEERING

TIME: 3 Hours

FULL MARKS: 50

INSTRUCTIONS:

1. The question paper contains 5 questions each of 10 marks and total 50 marks.
 2. Attempt all questions.
 3. The missing data, if any, may be assumed suitably.
 4. Before attempting the question paper, be sure that you have got the correct question paper.
 5. Tables/Data hand book/Graph paper etc. to be supplied to the candidates in the examination hall.
-

- Q.1(a) Define i) Super Mesh ii) Dependent Voltage Source iii) passive element iv) ideal current source [2] CO BL
CO1 1
- The voltage across a 100 F capacitor is shown in figure. Find the current flowing through it and draw respective profile. [3]

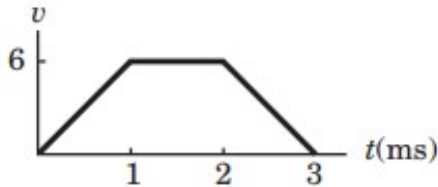

- Q.1(b) Find the resistance across terminal AB for the circuit shown below. [5] CO1 3

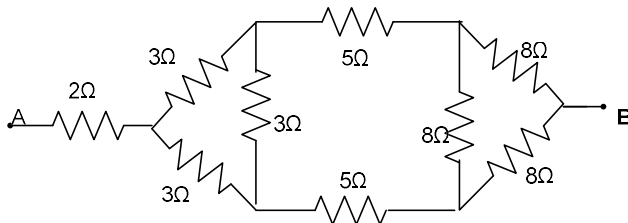

- Q.2(a) Evaluate the current supplied by the dependent current source and the power supplied by the independent voltage source in the circuit shown. The output of the dependent current source is dependent upon the voltage across the 2 ohm resistor. [2+3] CO2 3

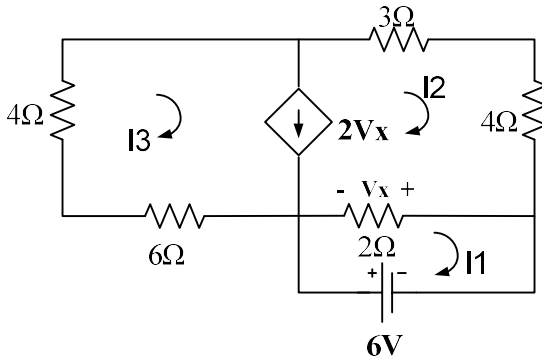

- Q.2(b) State and determine efficiency using the Maximum Power Transfer theorem. [5] CO2 2

PTO

- Q.3(a) i) Converts the sinusoids corresponding to these phasors. [2+3] CO3 3
 a) $v = -10\angle 30^\circ$ Volt
 b) $I = j(5 - j12)$ Amp.
 ii) Two element connected in series circuit consumes 700 watt and has power factor of 0.707 leading. If the applied voltage is $v = 141\sin(314t + 30^\circ)$ find the circuit constants.
- Q.3(b) A series resonant circuit has an impedance of 500Ω at resonant frequency and cut off frequencies are 10 KHz and 100 KHz. Determine a) the resonant frequency b) value of R,L,C c) quality factor at resonant frequency d) p.f. of the circuit at resonant frequency. [5] CO3 3
- Q.4(a) A balanced Delta connected load of $16 + j12 \Omega$ /phase is connected to three phase 400 volts supply. Find the phase current, line current, power factor, power, reactive power and total VA draw its phasor. [5] CO4 3
- Q.4(b) Obtain the mathematical equation for measuring the circuit's overall power factor in order to measure the power of a three-phase circuit using a two-wattmeter approach. [5] CO4 4
- Q.5(a) A coil of 600 turn and of resistance of 20Ω is wound uniformly over steel ring of mean circumference of 30 cm and cross-sectional area 9 cmsq . It is connected to supply of 20v. If the relative permeability of the ring is 1600 find a) Reluctance b) magnetic field intensity c) mmf and flux. [5] CO5 3
- Q.5(b) Two coils having 80 and 350 turns respectively are wound side by side on closed iron circuit of mean length 2.5 m with cross-sectional area of 200 cmsq . Calculate mutual inductance between coil. ($\mu_r = 2700$) [5] CO5 3

::::::01/05/2025::::::E