

BIRLA INSTITUTE OF TECHNOLOGY, MESRA, RANCHI
(MID SEMESTER EXAMINATION SP/2025)

CLASS: BTECH
BRANCH: ECE

SEMESTER: VI/ADD
SESSION : SP/2025

SUBJECT: EC353 CONTROL SYSTEM

TIME: 02 Hours

FULL MARKS: 25

INSTRUCTIONS:

1. The question paper contains 5 questions each of 5 marks and total 25 marks.
2. Attempt all questions.
3. The missing data, if any, may be assumed suitably.
4. Tables/Data handbook/Graph paper etc., if applicable, will be supplied to the candidates

- | | | CO | BL |
|---|-----|----|----|
| Q.1(a) Explain the difference between open-loop and closed-loop control systems with suitable examples. How does feedback influence the overall gain of a closed-loop system? | [2] | 1 | 2 |
| Q.1(b) A unity feedback system has an open-loop transfer function: | [3] | 1 | 3 |
| $G(s) = \frac{50}{s(s+6)}$ | | | |
| (i) Determine the overall gain of the closed-loop system. | | | |
| (ii) Analyze how feedback influences the system's stability. | | | |
| (iii) Explain how the system responds to external disturbances in the presence of feedback. | | | |
| Q.2(a) Classify control systems based on the following criteria and provide one example for each: | [2] | 1 | 2 |
| (i) Linear vs. Nonlinear control systems | | | |
| (ii) Time-invariant vs. Time-varying control systems | | | |
| Q.2(b) Analyze the effect of feedback on disturbance of the control system as shown below | [3] | 1 | 2 |

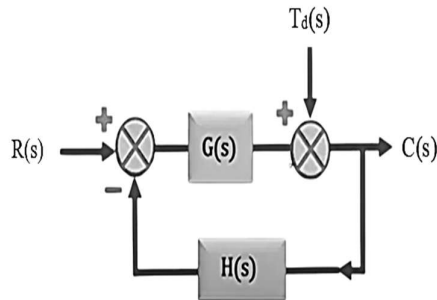

- | | | | |
|--|-----|---|---|
| Q.3(a) Explain the role of sensors in a control system. Discuss the working principle of a potentiometer as a feedback device. | [2] | 2 | 2 |
| Q.3(b) The block diagram of a system is shown in the figure. | [3] | 2 | 3 |

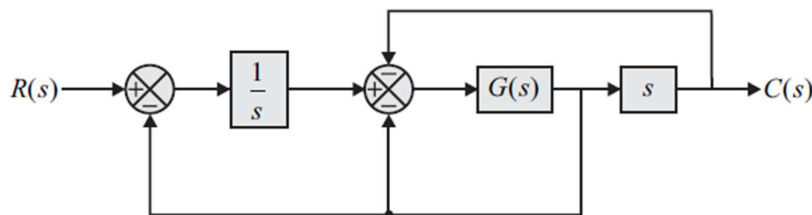

If the desired transfer function of the system is

$$\frac{C(s)}{R(s)} = \frac{s}{s^2 + s + 2}$$

Find $G(s)$

PTO

- Q.4(a) Describe the basic properties of Signal Flow Graphs (SFG). How do they differ from block diagrams in control system representation? [2] 2 2
- Q.4(b) Draw the signal flow graph for a control system whose block diagram is shown in the figure below. Use Mason's gain formula to determine C/R [3] 2 3

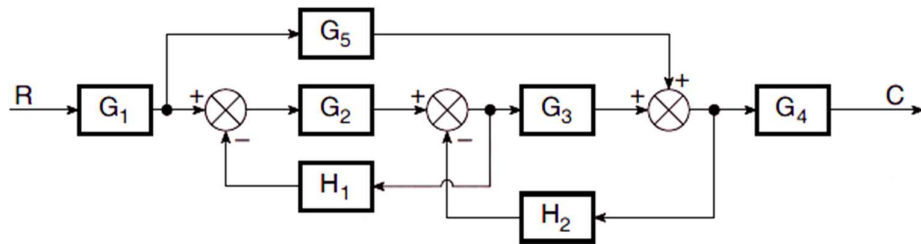

- Q.5(a) What do you mean by time constant of a system? What does it indicate? [2] 3 2
- Q.5(b) A unity feedback control system is characterised by the following open-loop transfer function: [3] 3 2

$$G(s) = \frac{0.4s + 1}{s(s + 0.6)}$$

Determine its transient response for a unit-step input.

.....28/02/2025.....E