

**BIRLA INSTITUTE OF TECHNOLOGY, MESRA, RANCHI
(MID-SEMESTER EXAMINATION SP/2025)**

**CLASS: B. TECH
BRANCH: ECE**

**SEMESTER: VI/ADD
SESSION: SP/2025**

SUBJECT: EC351 COMPUTER NETWORKING

TIME: 02 Hours

FULL MARKS: 25

INSTRUCTIONS:

1. The question paper contains 5 questions each of 5 marks and a total of 25 marks.
2. Attempt all questions.
3. The missing data, if any, may be assumed suitably.
4. Tables/Data handbook/Graph paper, etc., if applicable, will be supplied to the candidates

Q.1(a) Which MAC protocol will you prefer in a BUS topology with the following? [2] CO 1 BL 2

Q.1(b) In a 3-station ring architecture, which was the FDDI ring standard as MAC protocol, the following assumptions are true. [3] CO 1 BL 3

- i) Streamy traffic and heavy load, ii) Bursty traffic and light load.
- i) Traffic consists of fixed-length frames, ii) TTRT=100 frame times, iii) SAI= 30 frame times for each station, iv) The total overhead during one complete circulation is six frame times (2 frame time per station). The entries in the table below show one token circulation when no frames are sent. Assuming frames are sent from 2nd token circulation onwards, show the table entries for the next three token circulations.

Station A				Station B				Station C		
Arrival Time	TRT	SYNC	ASYN C	Arrival Time	TRT	SYNC	ASYN C	Arrival Time	TRT	SYNC
0	100	0	0	2	100	0	0	4	100	0

Q.2(a) Discuss the following: [2] CO 1 BL 2

- i) Carrier extension and frame bursting features of Gigabit Ethernet.
ii) Performance-related issues of Layer-2 switches and their remedies.

Q.2(b) Figure 1 shows an Internet configuration consisting of LANs and bridges. Assuming bridges B1 and B2 are currently out of order and minimum hops as the criterion, (If there is a tie, give preference to bridge with lower identifier i.e. B5 is preferred to B6 and so on). Form the central routing matrix (by taking source LANs in the column form and destination LANs in the row form) and routing tables for bridges B6, B10 and B15. [3] CO 1 BL 3

Q.3(a) In what way is the LLC layer for LANs different from other link layers? Explain with the help of examples in which type1, type2 and type 3 operations of LLC will be used. [2] CO 2 BL 2

Q.3(b) Figure 1 shows an internet configuration where costs are marked on the bridges. Assuming all the bridges are in working condition, form the spanning tree with B10 as the destination root bridge and mark all route ports, designated bridges, and designated ports. [3] CO 2 BL 3

Q.4(a) What are the enhancements made in IPv6 over IPv4? Explain the Flow label and payload length fields of the IPv6 header. [2] CO 2 BL 2

Q.4(b) What are the advantages of sub-netting? A company has been assigned the network 192.168.1.0/24 and wants to divide it into smaller subnets for different departments: [3] CO 2 BL 4

Department	Required Hosts
HR	50
IT	30
Sales	20
Admin	10

Create subnets that accommodate the required hosts, ensuring enough IPs for future growth. Mention the subnet mask, subnet address, Usable IP Range, and Broadcast address for each department in Tabular form.

Q.5(a) What are the pros and cons of limiting reassembly to the endpoint compared to allowing en route reassembly? [2] 2 2

Q.5(b) What is datagram lifetime? Explain its significance. [3] 2 3
 Suppose the maximum time an IP datagram can stay in the network before being delivered to the receiver is 60 sec (MSL: Maximum segment lifetime is 60 sec). What is the maximum rate at which a host should send out datagrams to avoid confusion during the reassembly of fragments at the receiver? Assume the datagram size of 2000 Bytes. Express the answer in Mbps.

:::::27/02/2025 E:::::

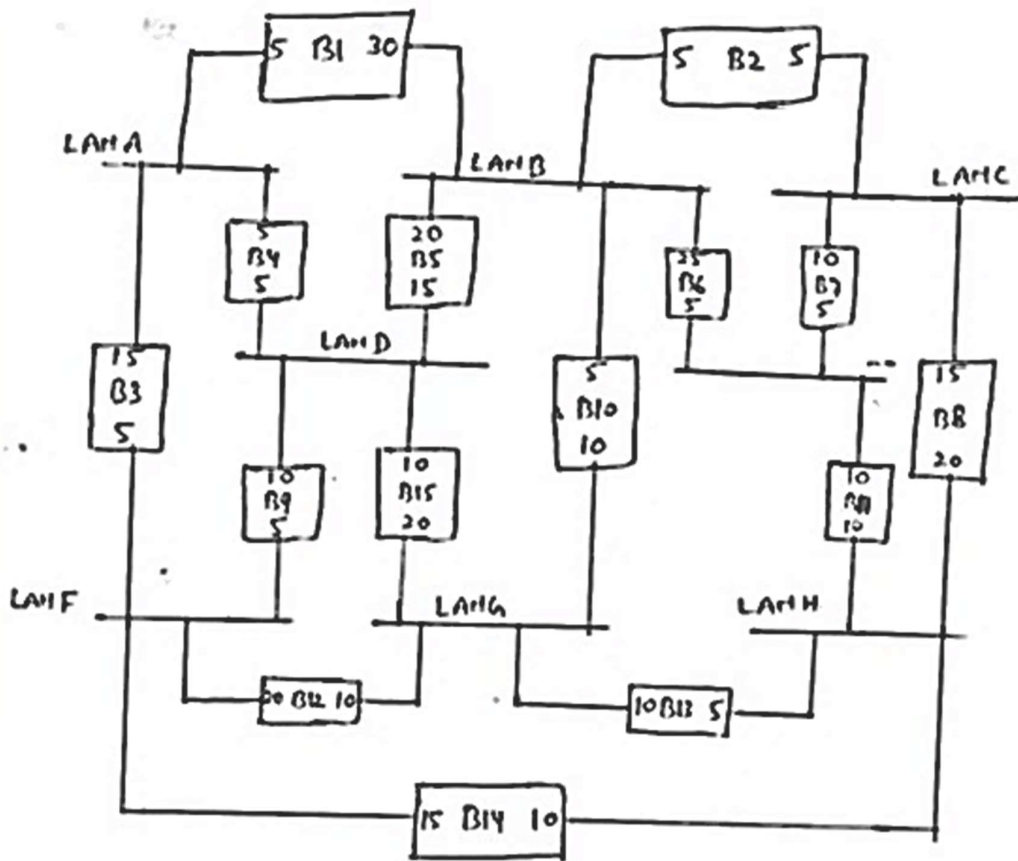

Figure-1