

BIRLA INSTITUTE OF TECHNOLOGY, MESRA, RANCHI  
(MID SEMESTER EXAMINATION SP/2025)

CLASS: BTECH  
BRANCH: CSE

SEMESTER : IV/ADD  
SESSION : SP/2025

SUBJECT: CS237 DATABASE MANAGEMENT SYSTEMS

TIME: 02 Hours

FULL MARKS: 25

**INSTRUCTIONS:**

1. The question paper contains 5 questions each of 5 marks and total 25 marks.
  2. Attempt all questions.
  3. The missing data, if any, may be assumed suitably.
  4. Tables/Data handbook/Graph paper etc., if applicable, will be supplied to the candidates
- 

			CO	BL
Q.1(a)	Why are integrity constraints required for DBMS? Discuss different integrity constraints with examples?	[2]	1	3
Q.1(b)	Assume we have the following application that models soccer teams, the games they play, and the players in each team. In the design, we want to capture the following: <ul style="list-style-type: none"><li>• We have a set of teams, each team has an ID (unique identifier), name, main stadium, and to which city this team belongs.</li><li>• Each team has many players, and each player belongs to one team. Each player has a number (unique identifier), name, DoB, start year, and shirt number that he uses.</li><li>• Teams play matches, in each match there is a host team and a guest team. The match takes place in the stadium of the host team.</li><li>• For each match we need to keep track of the following:<ul style="list-style-type: none"><li>○ The date on which the game is played</li><li>○ The final result of the match</li><li>○ The players participated in the match which will be stored in match_players. For each player, how many goals he scored, whether or not he took a yellow card, and whether or not he took a red card.</li><li>○ During the match, one player may substitute another player. We want to capture this substitution and the time at which it took place.</li></ul></li><li>• Each match has exactly three referees. For each referee we have an ID (unique identifier), name, DoB, years of experience. One referee is the main referee and the other two are assistant referee.</li></ul>	[3]	2	3
	Design an ER diagram to capture the above requirements. Specifically, mention your assumptions (if any).			
Q.2(a)	We can convert weak entity sets into strong entity sets by simply adding the appropriate attributes. Then, why are weak entity sets needed?	[2]	1	4
Q.2(b)	Discuss the following with suitable examples: a) Primary key    b) Candidate key    c) foreign key	[3]	2	2
Q.3(a)	Contrast and compare instances and schemas with reference to data base using suitable examples.	[2]	1	3
Q.3(b)	Describe the shortcoming of inner join in relational algebra. Illustrate the need for outer join operation. Explain different types of outer join operations with a suitable example.	[3]	2	2
Q.4(a)	Explain need for Views and Null values.	[2]	2	2
Q.4(b)	Consider the relational database supplier( <u>sid</u> , sname, address) parts( <u>pid</u> , pname, color) catlog( <u>sid</u> , <u>pid</u> , cost)	[3]	3	3

Write result in **relational algebra** for the following:

- i) Find the name of supplier who supplies some red parts.
- ii) Find the name of all part whose cost is more than Rs. 250.
- iii) Find the name of all part whose color is green.

PTO

Q.5(a) What do you mean by participation inheritance? Find the minimum numbers of tables [2] 3 3  
 required for the following ER diagram in relational model.

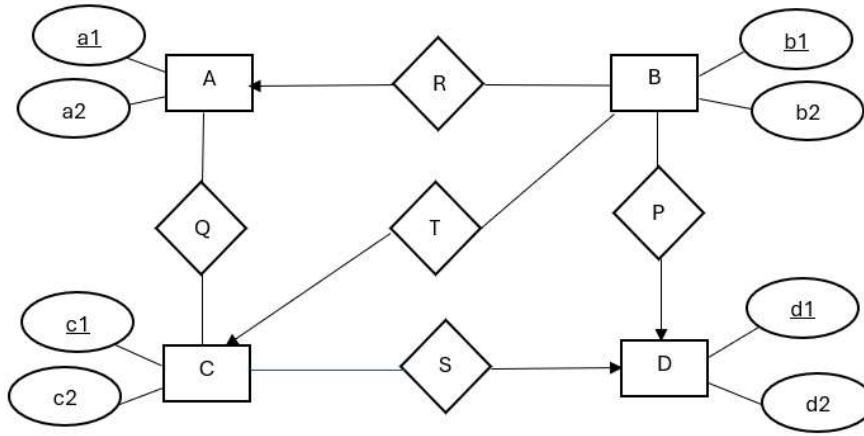

Q.5(b) Write the following queries in SQL (choose only one), using the following [3] 3 3  
 university schema.

*classroom*(building, room\_number, capacity)  
*department*(dept\_name, building, budget)  
*course*(course\_id, title, dept\_name, credits)  
*instructor*(ID, name, dept\_name, salary)  
*section*(course\_id, sec\_id, semester, year, building, room\_number, time\_slot\_id)  
*teaches*(ID, course\_id, sec\_id, semester, year)  
*student*(ID, name, dept\_name, tot\_cred)  
*takes*(ID, course\_id, sec\_id, semester, year, grade)  
*advisor*(s\_ID, i\_ID)  
*time\_slot*(time\_slot\_id, day, start\_time, end\_time)  
*prereq*(course\_id, prereq\_id)

- i. Find the ID and name of each student who has taken at least one course in the "Comp. Sci." department.
- ii. Find the names of all instructors in the computer science department together with the course id of all courses they taught.
- iii. Find the ID and name of each student who has not taken any course section in the year 2024.

:::::28/02/2025 E:::::