

**BIRLA INSTITUTE OF TECHNOLOGY, MESRA, RANCHI
(MID SEMESTER EXAMINATION MO/2024)**

**CLASS: B. Tech.
BRANCH: EEE**

**SEMESTER : V/ADD
SESSION : MO/2025**

SUBJECT: EE351 CONTROL THEORY

TIME: 02 Hours

FULL MARKS: 25

INSTRUCTIONS:

1. The question paper contains 5 questions each of 5 marks and total 25 marks.
2. Attempt all questions.
3. The missing data, if any, may be assumed suitably.
4. Tables/Data handbook/Graph paper etc., if applicable, will be supplied to the candidates

		CO	BL
Q.1(a) Define transfer function of a system? What is meant by order of a system? How it is decided for a physical system? State whether transfer function technique is applicable to non-linear system and whether the transfer function is independent of the input of a system.	[2]	1	1,2
Q.1(b) Explain the effect of feedback on (i) gain (ii) stability and (ii) external disturbance of the system.	[3]	1,3	2
Q.2(a) Define signal flow graph (SFG). List the properties of SFG.	[2]	1	1,2
Q.2(b) Using block diagram reduction technique, obtain the overall gain of the system shown in Fig. 1.	[3]	1	3
Q.3(a) Using Laplace transform, obtain the solution of differential equation given below: $\frac{d^2y(t)}{dt^2} + 3\frac{dy(t)}{dt} + 2y(t) = 5$ (assume zero initial conditions)	[2]	1,3	3
Q.3(b) Distinguish between transient response and steady state response of the system. The forward path transfer function of a system with unity feedback is given by $G(s) = \frac{10}{(s+2)(s+5)}$. Determine the damping ratio, undamped natural frequency of oscillation and %peak overshoot of the system.	[3]	1,3	3,4
Q.4(a) Define steady state error. Explain the importance of steady state error in designing a control system.	[2]	3	1,2
Q.4(b) For a unity feedback system, forward path transfer function is given by $G(s) = \frac{5(s^2+2s+100)}{s^2(s+2)(s^2+2s+20)}$. (i) Determine the type and order of the system. (ii) Determine the step, ramp and parabolic error coefficients. (iii) Examine the stability of the system using RH criteria.	[3]	3	4,5
Q.5 For a unity feedback system, open loop transfer function is given by $G(s)H(s) = \frac{K}{s(s+1)(s^2+4s+5)}$ a. Sketch the root locus for $0 \leq K \leq \infty$. b. Using the root locus, determine the value of K, at which the system becomes unstable. c. At this point of instability, determine the frequency of oscillation of the system.	[5]	2,3	4,5

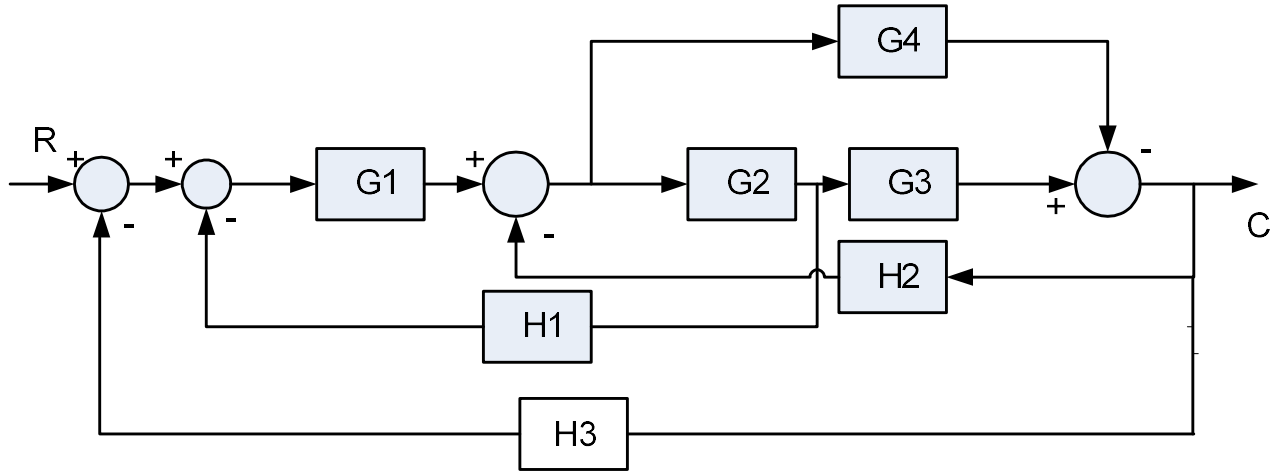

Fig. 1

.....19/09/2025.....M