

**CHOICE BASED CREDIT SYSTEM (CBCS) CURRICULUM**

*(Effective from Academic Session: Monsoon 2021)*

**NAME OF THE PROGRAMME**

**M.TECH. (Microwave Engineering)**



**Department of Electronics and Communication Engineering  
Birla Institute of Technology, Mesra, Ranchi - 835215 (India)**

## **Institute Vision**

To become a Globally Recognized Academic Institution in consonance with the social, economic and ecological environment, striving continuously for excellence in education, research and technological service to the National needs.

## **Institute Mission**

- To educate students at Undergraduate, Post Graduate Doctoral and Post-Doctoral levels to perform challenging engineering and managerial jobs in industry.
- To provide excellent research and development facilities to take up Ph.D. programmes and research projects.
- To develop effective teaching and learning skills and state of art research potential of the faculty.
- To build national capabilities in technology, education and research in emerging areas.
- To provide excellent technological services to satisfy the requirements of the industry and overall academic needs of society.

## **Department Vision**

To become a centre of excellence in teaching and research for creating technical manpower to meet the technological need of the country in the field of Electronics and Communications Engineering. Department exposes the undergraduate students to all fundamental and advanced technology in the field of Electronics and Communication.

## **Department Mission**

- To offer qualitative Electronics & Communication engineering education and professional ethics of global standards through innovative methods of teaching and learning with practical orientation so as to prepare students for successful career / higher study by providing excellent Technological Services to bridge the gap between Academics and Industry in order to fulfil the overall academic needs of the society.
- To provide high quality Course Structure in order to turn out qualified professionals to meet the engineering needs of the country.
- To carry out research through constant interaction with research organizations and industry.

## **M. Tech. (Microwave Engineering)**

### **Programme Educational Objectives (PEOs)**

- PEO1** To enable students in Microwave Engineering with expert and professionals in the present generation of Advanced communication techniques to develop the capability of independent research projects.
- PEO2** To train the postgraduate in Microwave Communication with the depth knowledge of various subject of present day interest like Advanced Electromagnetics, EMI/EMC, Microwave material, Microwave Imaging, Smart Antennas, Satellite & mobile Communication
- PEO3** To train the postgraduate having the knowledge of different simulation tools used for measure the performance and diagnose the RF and communication signals and systems.
- PEO4** To prepare students for Compiling and interpreting research data and presenting them in an appropriate format with scientific presentation, taking into consideration scientific principles and methodology, as well as practical applicability.
- PEO5** To train students a high level of autonomy, accountability, credibility, ethics, and responsibility for all personal work outputs in the advanced RF field.

### **Program Outcomes (POs)**

After completion of the programme, students will be able to demonstrate

- PO1** An ability to independently carry out research /investigation and development work to solve practical problems.
- PO2** An ability to write and present a substantial technical report/document.
- PO3** Students should be able to demonstrate a degree of mastery over the area as per the specialization of the program. The mastery should be at a level higher than the requirements in B. Tech program in Electronics & Communication Engg.
- PO4** Recognise the need for life long learning and will prepare oneself to understand, te, select and apply appropriate techniques and modern engineering and IT tools to solve complex Microwave Engineering for environment and society context.
- PO5** Design and implement an independent research project in Microwave Engineering applying research principles and methods .
- PO6** Acquire skills in handling instruments, tools, techniques and modelling using advanced software & tools.

### **Graduate Attributes (GAs)**

#### **GA1: Scholarship of Knowledge**

Acquire in-depth knowledge of specific discipline or professional area, including wider and global perspective, with an ability to discriminate, evaluate, analyse and synthesise existing and new knowledge, and integration of the same for enhancement of knowledge.

**GA2: Critical Thinking**

Analyse complex engineering problems critically, apply independent judgement for synthesising information to make intellectual and/or creative advances for conducting research in a wider theoretical, practical and policy context.

**GA3: Problem Solving**

Think laterally and originally, conceptualise and solve engineering problems, evaluate a wide range of potential solutions for those problems and arrive at feasible, optimal solutions after considering public health and safety, cultural, societal and environmental factors in the core areas of expertise.

**GA4: Research Skill**

Extract information pertinent to unfamiliar problems through literature survey and experiments, apply appropriate research methodologies, techniques and tools, design, conduct experiments, analyse and interpret data, demonstrate higher order skill and view things in a broader perspective, contribute individually/in group(s) to the development of scientific/technological knowledge in one or more domains of engineering.

**GA5: Usage of modern tools**

Create, select, learn and apply appropriate techniques, resources, and modern engineering and IT tools, including prediction and modelling, to complex engineering activities with an understanding of the limitations.

**GA6: Collaborative and Multidisciplinary work**

Possess knowledge and understanding of group dynamics, recognise opportunities and contribute positively to collaborative-multidisciplinary scientific research, demonstrate a capacity for self-management and teamwork, decision-making based on open-mindedness, objectivity and rational analysis in order to achieve common goals and further the learning of themselves as well as others.

**GA7: Project Management and Finance**

Demonstrate knowledge and understanding of engineering and management principles and apply the same to one's own work, as a member and leader in a team, manage projects efficiently in respective disciplines and multidisciplinary environments after consideration of economical and financial factors.

**GA8: Communication**

Communicate with the engineering community, and with society at large, regarding complex engineering activities confidently and effectively, such as, being able to comprehend and write effective reports and design documentation by adhering to appropriate standards, make effective presentations, and give and receive clear instructions.

**GA9: Life-long Learning**

Recognise the need for and have the preparation and ability to engage in life-long learning independently, with a high level of enthusiasm and commitment to improve knowledge and competence continuously.

**GA10: Ethical Practices and Social Responsibility**

Acquire professional and intellectual integrity, professional code of conduct, ethics of research and scholarship, consideration of the impact of research outcomes on professional practices and an understanding of responsibility to contribute to the community for sustainable development of society.

**GA11: Independent and Reflective Learning**

Observe and examine critically the outcomes of one's actions and make corrective measures subsequently and learn from mistakes without depending on external feedback.

**BIRLA INSTITUTE OF TECHNOLOGY- MESRA, RANCHI**  
**NEWCOURSE STRUCTURE -To be effective from academic session 2021- 22 Based on CBCS & OBE model**

**Recommended scheme of study for M.Tech. in Microwave Engineering**

SEMESTER / Session of Study (Recommended)	Course Level	Category of course	Course Code	Courses	Mode of delivery & credits <i>L-Lecture; T-Tutorial; P-Practical</i>			Total Credits <i>C- Credits</i>	
					<b>L</b> <i>(Periods/week)</i>	<b>T</b> <i>(Periods/week)</i>	<b>P</b> <i>(Periods/week)</i>		
<b>FIRST / Monsoon</b>	<b>FIFTH</b>	Programme Core (PC)	<b>EC501</b>	Microwave Semiconductor Devices	3	0	0	3	
			<b>EC503</b>	Antennas and Diversity	3	0	0	3	
			<b>EC505</b>	Advanced Electromagnetic Engineering	3	0	0	3	
			<b>EC506</b>	Electromagnetic Interference & Electromagnetic Compatibility	3	0	0	3	
		Programme Elective		PE-I	3	0	0	3	
		<b>LABORATORIES</b>							
		Programme Core (PC)	<b>EC502</b>	Microwave Measurement Lab	0	0	4	2	
			<b>EC504</b>	Antenna Lab.	0	0	4	2	
<b>TOTAL</b>								<b>19</b>	
<b>SECOND / Spring</b>	<b>FIFTH/ SIXTH</b>	Programme Core (PC)	<b>EC550</b>	Microwave & Mm-wave Integrated Circuits and	3	0	0	3	
			<b>EC551</b>	RF Circuit Design	3	0	0	3	
			<b>EC553</b>	Numerical Techniques in Electromagnetics	3	0	0	3	
		Programme Elective (PE)		PE-II	3	0	0	3	
		Programme Elective (PE)		PE-III	3	0	0	3	
		<b>LABORATORIES</b>							
		Programme Core (PC)	<b>EC552</b>	Microwave Integrated Circuit Lab	0	0	4	2	
			<b>EC554</b>	Computational Electromagnetics Lab	0	0	4	2	
<b>TOTAL FOR FIFTH LEVEL</b>								<b>38</b>	
<b>THIRD / Monsoon</b>	<b>SIXTH</b>	Programme Core	EC600	Thesis (Part I)				8	
		Open Elective		<b>OE I / MOOC</b>	3	0	0	3	
				<b>OE II / MOOC</b>	3	0	0	3	
		<b>TOTAL</b>							
<b>FOURTH / Spring</b>	<b>SIXTH</b>	Programme Core (PC)	EC650	Thesis (Part II)	0	0	16	16	
		<b>TOTAL</b>							
<b>TOTAL FOR SIXTH LEVEL</b>								<b>30</b>	
<b>GRAND TOTAL FOR M.TECH PROGRAMME (38 + 30)</b>								<b>68</b>	

**List of Programme Elective (PE)(choose one from each)**

<b>PE-I</b>	EC507	Electromagnetic and Microwave Applications of Metamaterials
	EC508	Radar Signal Analysis
	EC509	RF Microelectronics Circuit Design
<b>PE-II</b>	EC555	Advanced Array Synthesis
	EC556	RF Micro-Electro-Mechanical System
	EC557	Microwave Photonics
	EC558	Modern Optimization Techniques
	EC559	Mixed Signal VLSI Design
<b>PE-III</b>	EC517	Satellite Based Wireless communication
	EC603	mm wave Wireless Communications
	EC604	Microwave Measurement and Material Characterization

\* PROGRAMME ELECTIVES TO BE OPTED ONLY BY THE DEPARTMENT STUDENT

**DEPARTMENT OF ECE**  
**PROGRAMME ELECTIVES (PE)\***  
**OFFERED FOR LEVEL 5-6 of M. Tech. in Microwave Engineering**

PE / Level	Code no.	Name of the PE courses	Prerequisite/Corequisite courses with code	L	T	P	C
PE-I / Level-5 (MO)	EC507	Electromagnetic and Microwave Applications of Metamaterials	EC323 Microwave Theory & Techniques	3	0	0	3
	EC508	Radar Signal Analysis	EC323 Microwave Theory & Techniques, EC365 Radar & Navigation	3	0	0	3
	EC509	RF Microelectronics Circuit Design	EC201 Electronic Devices, EC253-R1 Analog Circuits	3	0	0	3
PE-II / Level-5 (SP)	EC555	Advanced Array Synthesis	EC327-R1 Antenna and Wave Propagation	3	0	0	3
	EC557	Microwave Photonics	EC323 Microwave Theory & Techniques, EC201 Electronics Devices, EC425 Optoelectronics Devices	3	0	0	3
	EC556	RF Micro-Electro-Mechanical system	EE101 Basics of Electrical Engineering, ME101 Basics of Mechanical Engineer, EC323 Microwave Theory & Techniques				
	EC558	Modern Optimization Techniques	MA203 Numerical Methods, MA204 Numerical Methods Lab	3	0	0	3
	EC559	Mixed Signal VLSI Design	EC253-R1 Analog Circuits, EC203 Digital system Design	3	0	0	3
PE-III / Level-6 (MO)	EC517	Satellite Based Wireless communication	EC367 Wireless Networks, EC417-R1 Satellite Communication	3	0	0	3
	EC603	mm wave Wireless Communications	EC323 Microwave Theory & Techniques, EC367 Wireless Networks	3	0	0	3
	EC604	Microwave Measurement and Material Characterization	EC323 Microwave Theory and Techniques, EC313 Electronic Measurements	3	0	0	3

\* PROGRAMME ELECTIVES TO BE OPTED ONLY BY THE DEPARTMENT STUDENT

**DEPARTMENT OF ECE OPEN ELECTIVES (OE)\***  
**OFFERED FOR LEVEL 5-6 of M. Tech. in Microwave Engineering**

OE / LEVEL	Code no.	Name of the OE courses	Prerequisites courses with code	L	T	P	C
OE/Level-5 (MO)	EC547	Fundamentals of MEMS		3	0	0	3
OE/Level-5 (SP)	EC597	Fundamentals of Microwaves		3	0	0	3

\* OPEN ELECTIVES TO BE OPTED ONLY BY OTHER DEPARTMENT STUDENTS

# **FIRST SEMESTER**

## **PROGRAMME CORE**

### **COURSE INFORMATION SHEET**

**Course code: EC501**

**Course title: Microwave Semiconductor devices**

**Pre-requisite(s): EC201 Electronics Devices**

**Co- requisite(s):**

**Credits: L: 3 T: 0 P: 0 C:3**

**Class schedule per week: 03**

**Class: M. Tech.**

**Semester / Level: I/05**

**Branch: ECE**

**Name of Teacher:**

#### **Course Objectives:**

This course enables the students to:

A.	Understand the Material Properties of Semiconductors.
B.	Grasp the principle of operation of Microwave BJTs, HBTs, and Tunnel Diodes and apply the same.
C.	Appraise and analyse the characteristics of Microwave Field Effect Transistors.
D.	Evaluate the characteristics of Transferred Electron Devices (TEDs).
E.	Comprehend the characteristics of Avalanche Transit-Time Devices and create their structures.

#### **Course Outcomes:**

After the completion of this course, a student will be able to:

1.	Describe and illustrate the Material Properties of Semiconductors.
2.	Sketch and explain the characteristics of Microwave BJTs, HBTs and Tunnel Diodes.
3.	Illustrate with the sketch of the structure of Microwave Field Effect Transistors, diagram their characteristics and analyze them.
4.	Appraise the principle of operation Transferred Electron Devices (TEDs), schematize their characteristics, assess and summarize their features.
5.	Schematize the structure and design Avalanche Transit-Time Devices to observe

high frequency response. Schematize their characteristics and prepare an inference.
---

## **Syllabus**

### **Module-1: Material Properties of Semiconductors:**

Frequency range for semiconductor materials, Crystalline structure of Si, Strain of SiGe films grown on Si, Crystalline structure of GaAs, wafer orientation for semi-insulating GaAs, Orientation-dependent etching profiles of GaAs, Energy bandgaps of GaAs, Si, and Ge as a function of temperature, Electron velocity for Si, InP and GaAs, Relative dielectric constant of GaAs, Thermal conductivity of various materials, II-V heterostructures used for Microwave and RF Applications, Energy bandgap and associated lattice constants for II-V heterostructures, Double pulsed doped pseudomorphic HEMT layer structure, InP, SiC, GaN, Comparison of conventional and wide bandgap materials. [8]

### **Module 2: Microwave Transistors and Tunnel Diodes:**

Microwave Bipolar Transistors: Physical Structures, Bipolar Transistor Configurations, Principles of Operation, Amplification Phenomena, Power-Frequency Limitations; Heterojunction Bipolar Transistors (HBTs): Physical Structures, Operational Mechanism, Electronic Applications; Microwave Tunnel Diodes: Principles of Operation, Microwave Characteristics. [8]

### **Module 3: Microwave Field Effect Transistors:**

Junction Field-Effect Transistors (JFETs): Physical Structure, Principles of Operation, Current-Voltage (I-V) Characteristics; Metal-Semiconductor Field-Effect Transistors (MESFETs): Physical Structures, Principles of Operation, Small-Signal Equivalent Circuit, Drain Current  $I_d$ , Cutoff Frequency  $f_{co}$  and Maximum Oscillation Frequency  $f_{max}$ ; High Electron Mobility Transistors (HEMTs): Physical Structure, Operational Mechanism, Performance Characteristics, Electronic Applications; Metal-Oxide-Semiconductor Field-Effect Transistors (MOSFETs): Physical Structure, Electronic Mechanism, Modes of Operation, Drain Current and Transconductance, Maximum Operating Frequency, Electronic Applications. [8]

### **Module 4: Transferred Electron Devices (TEDs):**

Gunn-Effect Diodes-GaAs Diode: Background, Gunn Effect; Ridley-Watkins--Hilsum (RWH) Theory: Differential Negative Resistance, Two-Valley Model Theory, High-Field Domain; Modes of Operation: Gunn Oscillation Modes, Limited-Space-Charge Accumulation (LSA) Mode, Stable Amplification Mode; LSA Diodes, InP Diodes, CdTe Diodes; Microwave Generation and Amplification. [8]

### **Module 5: Avalanche Transit-Time Devices:**

Read Diode: Physical Description, Avalanche Multiplication, Carrier Current  $I_0(t)$  and External Current  $I_e(t)$ , Output Power and Quality Factor Q; IMPATT Diodes: Physical Structures, Negative Resistance, Power Output and Efficiency; TRAPATT Diodes: Physical Structures, Principles of Operation, Power Output and Efficiency; BARITT Diodes: Physical Description, Principles of Operation, Microwave Performance; Parametric Devices: Physical Structures, Applications. [8]

## **TEXTBOOKS:**



1. Mike Golio, The RF and Microwave Handbook, 2e, CRC Press, 2008.
2. Samuel Y. Liao, Microwave Devices and Circuits, 3e, Prentice-Hall of India, 2003.

**REFERENCE BOOKS:**

1. S. M. Sze, Kwok K. Ng, Physics of Semiconductor Devices, 3e, Wiley-Interscience, 2006.
2. Stephen A. Campbell, The Science and Engineering of Microelectronic Fabrication, 2/e, Oxford University Press, 2001.
3. I. A. Glover, S. R. Pennock and P. R. Shepherd, Microwave Devices, Circuits and Subsystems for Communications Engineering, John Wiley & Sons, 2005.

**COURSE OUTCOME (CO) ATTAINMENT ASSESSMENT TOOLS & EVALUATION PROCEDURE**

**DIRECT ASSESSMENT**

Assessment Tool	% Contribution during CO Assessment
Quizzes (3)	3x10 = 30
Seminar	10
Teacher's Assessment	10
Semester End Examination	50

**INDIRECT ASSESSMENT –**

1. Students' Feedback on Course Outcome

**MAPPING OF COURSE OUTCOMES ONTO PROGRAM OUTCOMES**

CO	PO1	PO2	PO3	PO4	PO5	PO6
CO1	3	3	3	3	2	1
CO2	3	3	3	3	2	1
CO3	3	3	1	3	2	1
CO4	2	2	2	2	3	1
CO5	2	2	2	2	3	1

Correlation Levels 1, 2 or 3 as defined below:

1: Slight (Low) 2: Moderate (Medium) 3: Substantial (High)

**Gaps in the syllabus (to meet Industry/Profession requirements):** Hands-on-practical for Microwave Device fabrication.

**POs met through Gaps in the Syllabus:** PO6 will be met through Microwave Device design-based assignment, which involves handling of TCAD tools.

**Topics beyond syllabus/Advanced topics/Design:** Topics beyond syllabus/advanced topics will be covered through the allotment of assignment requiring handling of TCAD tools and simulations.

**POs met through Topics beyond syllabus/Advanced topics/Design:** PO6

**Course Delivery Methods**

CD	Course Delivery methods
CD1	Lecture by use of boards/LCD projectors/OHP projectors
CD2	Assignments
CD3	Laboratory experiments/Teaching aids/Seminars
CD4	Mini Projects
CD5	Industrial visits/in-plant training
CD6	Self- learning such as use of NPTEL materials and internets
CD7	Simulation

**MAPPING BETWEEN COURSE OUTCOMES AND COURSE DELIVERY METHOD**

Mapping Between COs and Course Delivery (CD) methods	
Course Outcomes	Course Delivery Method
CO1	CD1, CD2, CD3, CD7
CO2	CD1, CD2, CD3, CD7
CO3	CD1, CD2, CD3, CD7
CO4	CD1, CD2, CD3, CD6, CD7
CO5	CD1, CD2, CD3, CD6, CD7

**COURSE INFORMATION SHEET**

**Course code:** EC503

**Course title:** Antennas and Diversity

**Pre-requisite(s):** EC257 Electromagnetic Fields and Waves, EC323 Microwave Theory & Techniques

**Credits: L: 3 T: 0 P: 0 C:3**

**Class schedule per week: 03**

**Class: M. Tech.**

**Semester / Level: I/05**

**Branch: ECE**

**Name of Teacher:**

**Course Objectives:** This course enables the students to:

A.	Develop and apply the mathematical tools to analyse radiation characteristics of aperture antennas.
B.	Design and analyse various broadband, high gain, planar antennas for wireless applications.
C.	Design and analyse the dielectric resonator antenna
D.	Understand the concept of smart antenna and beam forming techniques by using cellular radio system and its evolution
E.	Explain the need of different diversity schemes used in wireless communication

**Course Outcomes:**

After the completion of this course, a student will be able to:

1.	Understand the concept of aperture antennas, dielectric resonator antennas and their applications
2.	Develop the mathematical tool to analyse radiation characteristics of antennas for wireless applications
3.	Design the various types of aperture, dielectric resonator antennas to evaluate its performance
4.	Explain and compare different diversity scheme, smart antennas and algorithms.
5.	Combine different diversity scheme to enhance system performance

## **Syllabus**

### **Module 1: Aperture Antennas**

Radiation Equations, Rectangular Apertures: Uniform Distribution on an infinite ground plane, Uniform distribution in Space, Circular Apertures: Uniform Distribution on an infinite ground plane, Design Considerations. [8]

### **Module 2: Antennas for Wireless Communication**

: Helical, Normal mode, Axial mode, Design procedure, feed design for helical antenna, Horn Antenna; E-Plane, H-Plane, Pyramidal horn, Whip antenna, Discone antenna. [8]

### **Module 3: Dielectric Resonator Antenna:**

Introduction to Dielectric Resonator Antennas. Major Characteristics, Simple-Shaped Dielectric Resonator Antennas - The Hemispherical DRA. The Cylindrical DRA. The Rectangular DRA, Coupling to DRAs, Hybrid DRAs Bandwidth Enhancement of DRAs, Low Profile and Compact DRAs, DRAs with High Dielectric Constants, Circular-Polarized and Dual-Polarized DRAs, Ferrite Resonator Antennas. [8]

#### Module 4: Smart Antenna

Introduction, Cellular Radio Systems Evolution, Signal propagation, Diversity and Combining Techniques, Smart Antenna System, Benefits and drawbacks of Smart Antennas, Antenna beamforming.

[8]

#### Module 5: Diversity Schemes

Macroscopic diversity scheme, Microscopic diversity scheme – Space diversity, Field diversity, Polarization diversity, Angle diversity, Frequency diversity and time diversity scheme. Combining techniques for Macroscopic diversity, Combining techniques for Microscopic diversity.

[8]

#### TEXTBOOKS:

1. Antenna Theory, Analysis and Design, 3/E, A. Balanis, John Wiley.
2. Antennas, J. D. Kraus, TMH
3. Wireless Communications, Principles and Practices, Rappaport, PHI

#### REFERENCE BOOKS:

1. Software Radio A Modern Approach to Radio Engineering, J. H. Reed, Pearson Education.
2. Wireless and Cellular Communications, William C. Y. Lee, McGraw-Hill.
3. Wireless Communications, Principles and Practices, Rappaport, PHI.
4. Smart Antenna, T. K. Sarkar.

### COURSE OUTCOME (CO) ATTAINMENT ASSESSMENT TOOLS & EVALUATION PROCEDURE

#### DIRECT ASSESSMENT

Assessment Tool	% Contribution during CO Assessment
Quizzes (3)	3x10 = 30
Seminar	10
Teacher's Assessment	10
Semester End Examination	50

#### INDIRECT ASSESSMENT –

1. Students' Feedback on Course Outcome

#### MAPPING OF COURSE OUTCOMES ONTO PROGRAM OUTCOMES

CO	PO1	PO2	PO3	PO4	PO5	PO6
CO1	3	2	1	3	1	2
CO2	3	2	1	3	2	1
CO3	3	1	2	3	2	1

CO4	3	2	2	3	2	2
CO5	3	3	3	3	3	3

Correlation Levels 1, 2 or 3 as defined below:

1: Slight (Low) 2: Moderate (Medium) 3: Substantial (High)

**Gaps in the syllabus (to meet Industry/Profession requirements):** Design and Development of real-time industrial projects.

**POs met through Gaps in the Syllabus:** PO4 & PO5

**Topics beyond syllabus/Advanced topics/Design:** Design optimization for industrial and Research projects.

**POs met through Topics beyond syllabus/Advanced topics/Design:** PO4 & PO5

### Course Delivery Methods

CD	Course Delivery methods
CD1	Lecture by use of boards/LCD projectors/OHP projectors
CD2	Assignments
CD3	Laboratory experiments/Teaching aids/Seminars
CD4	Mini Projects
CD5	Industrial visits/in-plant training
CD6	Self- learning such as use of NPTEL materials and internets
CD7	Simulation

### MAPPING BETWEEN COURSE OUTCOMES AND COURSE DELIVERY METHOD

Course Outcomes	Course Delivery Method
<b>Mapping Between COs and Course Delivery (CD) methods</b>	
CO1	CD1, CD6
CO2	CD1, CD2, CD3, CD7
CO3	CD1, CD2, CD3, CD6, CD7
CO4	CD1, CD3, CD6, CD7
CO5	CD1, CD2, CD3, CD4, CD5, CD7

# COURSE INFORMATION SHEET

**Course code:** EC505

**Course title:** Advanced Electromagnetic Engineering

**Pre-requisite(s):** Electromagnetic Theory and Microwave Engineering

**Co- requisite(s):**

**Credits:** L: 3 T: 0 P: 0 C: 3

**Class schedule per week:** 03

**Class:** M. Tech.

**Semester / Level:** I/05

**Branch:** ECE

**Course Objectives:** This course enables the students to:

A.	To develop an ability to analyse the plane waves functions and various rectangular shaped microwave components and their properties for different modes in rectangular coordinate system.
B.	To develop an ability to analyse the cylinder wave functions and various cylindrical shaped microwave components and their properties for different modes in cylindrical coordinate systems.
C.	To develop an ability to evaluate the spherical wave functions and various spherical shaped microwave components and their properties for different modes in spherical coordinate systems
D.	To develop and ability to evaluate different parameters of microwave components using perturbational and variational techniques.
E.	To develop and ability to analyse the various microwave networks

**Course Outcomes:**

After the completion of this course, a student will be able to:

1.	Demonstrate understanding on the plane waves functions and calculation of various performance parameters of different kinds of rectangular microwave components such as; rectangular waveguide, rectangular cavity, partially filled waveguide and dielectric slab waveguide apart from the concepts of surface guided waves and modal expansion of fields
2.	Have an ability to analyse the cylindrical wave functions and calculation of various performance parameters of different kinds of cylindrical microwave components such as; circular waveguide, circular cavity, parallel plate, partially filled, dielectric slab coated and corrugated radial waveguides apart from the concepts of sources of cylindrical waves, two-dimensional radiation and wave transformations.
3.	Have an ability to understand the spherical wave functions and evaluation of various performance parameters of spherical cavities, Conical Shaped Spherically Radial

	Waveguide, Hemispherical Resonator apart from the concepts of orthogonality relationship, space as a waveguide, waveform transformation techniques and scattering by spheres.
4.	Demonstrate insight to use the perturbational and variational techniques to evaluate the different parameters due to perturbations on cavity walls, cavity materials and waveguide apart from the knowledge of stationary formulas for cavity.
5.	Have an ability to understand the concepts of various microwave networks

## **Syllabus**

### **Module-1: The Wave Functions**

Plane Waves, Rectangular Waveguide, Alternative Mode Sets, The Rectangular Cavity. Partially Filled Waveguide, Surface Guided Waves, Modal Expansion of Fields. Currents in Waveguides.

[8]

### **Module-2: Cylindrical Wave Functions**

The Wave Functions, Circular Waveguide, Radial Waveguides, Partially Filled Radial Waveguide, Sources of Cylindrical Waves, Two-Dimensional Radiation, Wave Transformations, Scattering by Cylinders.

[8]

### **Module-3: Spherical Wave Functions**

The Wave Functions, Spherical Cavity, Orthogonality Relationships, Sources of Spherical Waves, Wave Transformations, Scattering by Spheres, Maximum Antenna Gain.

[8]

### **Module-4: Perturbational and Variational Techniques**

:

Perturbation of Cavity Walls, Cavity Material Perturbations, Waveguide Perturbations, Stationary Formulas for Cavities, The Reaction Concept, Stationary Formulas for Waveguide, Spectral Domain Analysis .

[8]

### **Module-5: Microwave Networks**

Cylindrical Waveguide, Modal expansion of waveguides, the network Concept, One-port Network, Two-port Network, Obstacles in waveguide, Posts in waveguide, Waveguide Junctions, Probes in Cavities, Aperture Coupling in Cavities.

[8]

### **TEXTBOOKS:**

1. Time Harmonic Electromagnetic Fields; By Roger F. Harrington; McGraw Hill Book Company; 1961. (T1)

### **REFERENCE BOOKS:**

1. Foundations for Microwave Engineering; Second Edition; By Robert E. Collin; McGraw Hill International Edition; 1992. (R1)
2. Microwave Engineering; Second Edition; by David M. Pozar; John Wiley & Sons; Inc. Copyright 2001, (R2)

## COURSE OUTCOME (CO) ATTAINMENT ASSESSMENT TOOLS & EVALUATION PROCEDURE

### DIRECT ASSESSMENT

Assessment Tool	% Contribution during CO Assessment
Quizzes (3)	3x10 = 30
Seminar	10
Teacher's Assessment	10
Semester End Examination	50

**INDIRECT ASSESSMENT** –. Students' Feedback on Course Outcome

### MAPPING OF COURSE OUTCOMES ONTO PROGRAM OUTCOMES

CO	PO1	PO2	PO3	PO4	PO5	PO6
CO1	2	2	3	3	2	-
CO2	2	2	3	3	2	-
CO3	2	2	3	3	2	-
CO4	2	2	3	3	2	-
CO5	2	2	3	3	2	-

Correlation Levels 1, 2 or 3 as defined below:

1: Slight (Low) 2: Moderate (Medium) 3: Substantial (High)

**Gaps in the syllabus (to meet Industry/Profession requirements):** Design of advanced microwave components for industrial projects.

**POs met through Gaps in the Syllabus:** PO5 & PO6

**Topics beyond syllabus/Advanced topics/Design:** Analysis, design and optimization of advanced microwave components for industrial projects.

**POs met through Topics beyond syllabus/Advanced topics/Design:** PO5 & PO6

**Course Delivery Methods**



<b>CD</b>	<b>Course Delivery methods</b>
CD1	Lecture by use of boards/LCD projectors/OHP projectors
CD2	Assignments
CD3	Laboratory experiments/Teaching aids/Seminars
CD4	Mini Projects
CD5	Industrial visits/in-plant training
CD6	Self- learning such as use of NPTEL materials and internets
CD7	Simulation

### **MAPPING BETWEEN COURSE OUTCOMES AND COURSE DELIVERY METHOD**

<b>Mapping Between COs and Course Delivery (CD) methods</b>	
<b>Course Outcomes</b>	<b>Course Delivery Method</b>
CO1	CD1, CD6
CO2	CD1, CD6
CO3	CD1, CD2, CD6
CO4	CD1, CD2, CD6
CO5	CD1, CD2, CD6

## **COURSE INFORMATION SHEET**

**Course code:** EC506

**Course title:** Electromagnetic Interference and Electromagnetic Compatibility

**Pre-requisite(s):** Electromagnetic Theory

**Co- requisite(s):**

**Credits:** L: 3 T: 0 P: 0 C: 3

**Class schedule per week:** 03

**Class:** M. Tech.

**Semester / Level:** I/05

**Branch:** ECE

**Name of Teacher:**

**Course Objectives :** This course enables the students to

A.	Explain requirement of EMI & EMC concept and impart knowledge on different units and standards used for Electromagnetic compatibility in electronic/electric system.
B.	Develop an ability to analyse, measure and evaluate the radiated and conducted

	emissions to examine the compatibility.
C.	Develop an ability to analyse and evaluate the impact of EMI mitigation techniques such as shielding and grounding.
D.	Develop an ability to explain the impact of EMI on system design.
E.	Review the literature related to EMI & EMC to report it ethically.

### Course Outcomes

After the completion of this course, students will be able to:

1.	Explain the requirement of EMI & EMC concept and impart knowledge on different units and standards used for <u>Electromagnetic compatibility in electronic/electric system.</u>
2.	Analyse, measure and evaluate radiated and conducted emissions to examine the electromagnetic compatibility.
3.	Analyse and evaluate the impact of EMI mitigation techniques such as shielding and grounding.
4.	Explain the impact of EMI on system design.
5.	Review and write the literature related to EMI & EMC to report it ethically.

### Syllabus

#### Module 1: Introduction

A brief history of EMI/EMC, Analysis of EMI, Type of Noise and Interference, Electromagnetic Compatibility, Radiated Emission and susceptibility, Conducted Emission and Susceptibility, Benefits of good EMC Design, Brief description of EMC regulations, Examples of EMC related problems. EMC requirements for Electronic Systems: Government regulations, Requirement for Commercial products and Military products, Radiated Emission limits for Class A, Class B, FCC and CISPR, measurement of Emissions for verification of compliance: Radiated Emission and Conducted Emissions, Typical product emissions, Additional product requirements, design constraints for products, Advantages of EMC Design. [8]

#### Module 2: Conducted Emission and Susceptibility

Measurement of Conducted emission: LISN, Common and Differential mode currents, Power supply filters: Basic properties of filters, A generic power supply filter topology, Effect of filter elements on common and differential mode currents, Separation of conducted emissions into common and differential mode components for diagnostic purpose, Power supplies: Linear and SMPS, Effect of Power Supply Components on Conducted emissions, Power Supply and Filter placement, Conducted Susceptibility. [8]

#### Module 3: Radiated Emission and Susceptibility

Simple Emission models for wires and PCB lands: Differential mode versus Common mode currents, Differential mode current emission model Common mode current emission model, Current probes, Simple susceptibility models for wires and PCB lands: Shielded cables and surface transfer impedance. [8]

#### Module 4: Cross talk

Three conductor transmission lines and crosstalk, Transmission line equations for lossless lines, The per unit length parameters: Homogeneous versus Inhomogeneous media, Wide separation approximation for wires, Numerical methods for other structures, The Inductive-Capacitive Coupling Approximation model: Frequency

domain Inductive-Capacitive coupling model, Time domain Inductive-Capacitive coupling model, Lumped circuit approximate models. Shielded Wires: Per unit length parameters, Inductive and Capacitive Coupling, Effect of Shield grounding, Effect of pigtailed, Effects of Multiple shields, MTL model predictions, Twisted wires: Per unit length parameters, Inductive and Capacitive Coupling, Effects of Twist, Effects of Balancing.

[8]

### Module 5: Shielding

Shielding Effectiveness, Far field Sources: Exact solution, Approximate solution, Near field sources: Near field versus far field, Electric sources, Magnetic sources, Low frequency, magnetic field shielding, Effect of Apertures. System Design for EMC: Shielding and Grounding, PCB Design, System configuration and design, Electrostatic Discharge, Diagnostic tools.

[8]

### TEXTBOOKS:

1. Paul, C., Introduction to Electromagnetic Compatibility, John Wiley & Sons, 1992.

### REFERENCE BOOKS:

1. Ott, W. Henry, Electromagnetic Compatibility Engineering, John Wiley & Sons, 2009.

## COURSE OUTCOME (CO) ATTAINMENT ASSESSMENT TOOLS & EVALUATION PROCEDURE

### DIRECT ASSESSMENT

Assessment Tool	% Contribution during CO Assessment
Quizzes (3)	3x10 = 30
Seminar	10
Teacher's Assessment	10
Semester End Examination	50

### INDIRECT ASSESSMENT –

1. Students' Feedback on Course Outcome

## MAPPING OF COURSE OUTCOMES ONTO PROGRAM OUTCOMES

CO	PO1	PO2	PO3	PO4	PO5	PO6
CO1	2	1	1	2	1	3
CO2	2	1	1	1	1	1
CO3	2	1	2	2	3	-
CO4	2	2	2	2	2	2
CO5	1	2	2	3	2	2

Correlation Levels 1, 2 or 3 as defined below:

1: Slight (Low) 2: Moderate (Medium) 3: Substantial (High)

**Gaps in the syllabus (to meet Industry/Profession requirements):** Design of real-time industrial projects.

**POs met through Gaps in the Syllabus:** PO5 & PO6

**Topics beyond syllabus/Advanced topics/Design:** Design optimization for industrial projects.

**POs met through Topics beyond syllabus/Advanced topics/Design:** PO5 & PO6

### Course Delivery Methods

CD	Course Delivery methods
CD1	Lecture by use of boards/LCD projectors/OHP projectors
CD2	Assignments
CD3	Laboratory experiments/Teaching aids/Seminars
CD4	Mini Projects
CD5	Industrial visits/in-plant training
CD6	Self- learning such as use of NPTEL materials and internets
CD7	Simulation

### MAPPING BETWEEN COURSE OUTCOMES AND COURSE DELIVERY METHOD

Mapping Between COs and Course Delivery (CD) methods	
Course Outcomes	Course Delivery Method
CO1	CD1, CD6
CO2	CD1, CD6, CD7
CO3	CD1, CD2, CD3, CD6, CD7
CO4	CD1, CD3, CD6, CD7
CO5	CD1, CD2, CD3, CD4, CD7

## **PROGRAMME ELECTIVE – I**

### **COURSE INFORMATION SHEET**

**Course code:** EC507

**Course title:** Electromagnetic and Microwave Applications of Metamaterials

**Pre-requisite(s):** Electromagnetic Theory and Microwave Engineering

**Co- requisite(s):**

**Credits: L: 3 T: 0 P: 0 C: 3**

**Class schedule per week: 03**

**Class: M. Tech.**

**Semester / Level: I/05**

**Branch: ECE**

**Course Objectives:** This course enables the students to:

A.	To develop an ability to understand about left-handed metamaterial and its characteristics and properties
B.	To develop an ability to analyse the physical realization of left-handed metamaterials using the resonant approach.
C.	To develop an ability to analyse the physical realization of left-handed metamaterials using the non-resonant approach
D.	To develop and ability to understand the guided-wave applications of left-handed metamaterials
E.	To develop and ability to understand the radiated-wave applications of left-handed metamaterials

**Course Outcomes:**

After the completion of this course, a student will be able to:

1.	Demonstrate understanding of left-handed metamaterial and its characteristics and properties
2.	Have an ability to design the left-handed metamaterials using the resonant approach.
3.	Have an ability to design the left-handed metamaterials using the non-resonant approach
4.	Demonstrate insight the guided-wave applications of left-handed metamaterials.
5.	Demonstrate insight the radiated-wave applications of left-handed metamaterials.

## **Syllabus**

### **Module 1: Introduction to Metamaterials**

Definition of Metamaterials and left-handed Metamaterials. Theoretical speculation by Viktor Veselago. Wave Propagation in Left-Handed Media, Energy Density and Group Velocity, Negative Refraction, Fermat Principle, Inverse Doppler Effect, Backward Cerenkov Radiation, Negative Goos-Hanchen Shift, Waves at interfaces, Waves through left-handed slabs, Phase Compensation and Amplification of Evanescent Modes, Perfect Tunneling, The Perfect Lens, Losses and Dispersion.

[8]

### **Module 2: Realization of Metamaterials using Resonant Approach**

Scaling Plasmas at Microwave Frequencies, Metallic Waveguides and Plates as One- and Two-Dimensional Plasmas, Wire Media, Spatial Dispersion in Wire Media, Synthesis of Negative Magnetic Permeability, Design and Analysis of the Edge and Broad Coupled SRR, The Double and Multiple Split SRR, Spirals Resonators, Higher-Order Resonances in SRRs, Isotropic SRRs, Scaling Down SRRs to Infrared and Optical Frequencies , 1/2/3 Dimensional SRR-Based Left-Handed Metamaterials, Ferrite Metamaterials, Chiral Metamaterials.

[8]

### **Module 3: Realization of Metamaterials using Non-Resonant Approach**

:

Ideal homogeneous CRLH TLs, Fundamental TL Characteristics, Equivalent MTM Constitutive Parameters, Balanced and Unbalanced Resonances, lossy CRLH TL model, LC Network Implementation, Difference with Conventional Filters, Transmission Matrix Analysis, Input Impedance, Cutoff Frequencies, Analytical Dispersion Relation, Bloch Impedance, Real Distributed 1D CRLH Structures, General Design Guidelines, Microstrip Implementation, Parameters Extraction.

[8]

### **Module 4: Guided-Waves Applications of Metamaterials**

:

Dual-Band Components, Dual-Band Property of CRLH TLs, Quarter-Wavelength TL and Stubs, Quadrature Hybrid and Wilkinson Power Divider, Enhanced-Bandwidth Components, Principle of Bandwidth Enhancement, Rat-Race Coupler, Tight Edge-Coupled Coupled-Line Couplers, Generalities on Coupled-Line Couplers, Symmetric Impedance Coupler, Asymmetric Phase Coupler, Negative and Zeroth-Order Resonator. SRRs based Filters and Diplexers Design.

[8]

### **Module 5: Radiated-Wave Applications of Metamaterials**

:

Fundamental aspects of Leaky-Wave Structures, Principle of Leakage Radiation, Uniform and Periodic LW Structures, Backfire-to-Endfire (BE) leaky-wave (LW) antenna, electronically scanned LW antenna, Passive Retro-Directive Reflector, Two-Dimensional LW Radiation, Conical-Beam Antenna, Full-Space Scanning Antenna, Zeroth Order Resonating Antenna, Dual-Band CRLH-TL Resonating Ring Antenna, Heterodyne Phased Array, Non-uniform Leaky-Wave Radiator, The Future of MTMs.

[8]

### **TEXTBOOKS:**

1. Metamaterials with Negative Parameters, Theory, Design and Microwave Applications by Ricardo Marques, Ferran Martin, and Mario Sorolla “Wiley Series in Microwave and Optical Engineering, Wiley Intersciences 2007” (T1)
2. Electromagnetic Metamaterials: Transmission Line Theory and Microwave Applications, The Engineering Approach,” Christophe Caloz and Tatsuo Itoh, John Wiley & Sons, Inc., Hoboken, New Jersey 2006. (T2)

### **REFERENCE BOOKS:**

1. Foundations for Microwave Engineering; Second Edition; By Robert E. Collin; McGraw Hill International Edition; 1992. (R1)
2. Microwave Engineering; Second Edition; by David M. Pozar; John Wiley & Sons; Inc. Copyright 2001. (R2)

## **COURSE OUTCOME (CO) ATTAINMENT ASSESSMENT TOOLS & EVALUATION PROCEDURE**

### **DIRECT ASSESSMENT**

Assessment Tool	% Contribution during CO Assessment
Quizzes (3)	3x10 = 30
Seminar	10
Teacher's Assessment	10
Semester End Examination	50

**INDIRECT ASSESSMENT –**

1. Students' Feedback on Course Outcome

**MAPPING BETWEEN COURSE OUTCOMES AND COURSE DELIVERY METHOD**

CO	PO1	PO2	PO3	PO4	PO5	PO6
CO1	2	2	3	3	3	2
CO2	3	2	3	3	3	2
CO3	3	2	3	3	3	2
CO4	3	2	3	3	3	2
CO5	3	2	3	3	3	2

Correlation Levels 1, 2 or 3 as defined below:

1: Slight (Low) 2: Moderate (Medium) 3: Substantial (High)

**Gaps in the syllabus (to meet Industry/Profession requirements):** Design of advanced microwave components using left handed metamaterial.

**POs met through Gaps in the Syllabus:** PO2

**Topics beyond syllabus/Advanced topics/Design:** Analysis, design and optimization of advanced microwave components using left handed metamaterial for industrial projects.

**POs met through Topics beyond syllabus/Advanced topics/Design:** PO5 & PO6

**Course Delivery Methods**

CD	Course Delivery methods
CD1	Lecture by use of boards/LCD projectors/OHP projectors
CD2	Assignments
CD3	Laboratory experiments/Teaching aids/Seminars
CD4	Mini Projects
CD5	Industrial visits/in-plant training
CD6	Self- learning such as use of NPTEL materials and internets
CD7	Simulation

**MAPPING BETWEEN COURSE OUTCOMES AND COURSE DELIVERY METHOD**

Mapping Between COs and Course Delivery (CD) methods	
Course Outcomes	Course Delivery Method
CO1	CD1, CD6
CO2	CD1, CD6, CD7
CO3	CD1, CD2, CD6, CD7
CO4	CD1, CD2, CD6, CD7
CO5	CD1, CD2, CD6, CD7

**COURSE INFORMATION SHEET****Course code: EC508****Course title: Radar Signal Analysis****Pre-requisite(s): Microwave Engineering****Co- requisite(s):****Credits: L: 3 T: 0 P: 0 C: 3****Class schedule per week: 03****Class: M. Tech.****Semester / Level: I/05****Branch: ECE****Name of Teacher:****Course Objectives: This course enables the students to**

:

A.	To appraise an overview of Radar Systems.
B.	To perceive the Target Detection, Pulse Integration and Pulse Compression
C.	To grasp Matched Filter and Ambiguity Function-Analog and Discrete Coded Waveforms.



D.	To understand the concept of Radar Clutter.
E.	To grasp the Doppler and Adaptive Array Processing

**Course Outcomes:**

After the completion of this course, a student will be able to:

1	Able to explain the Radar Systems.
2	Able to demonstrate Target Detection, Pulse Integration and Pulse Compression
3	Able to explain Matched filter and Ambiguity Function-Analog and Discrete Coded Waveforms
4	Able to demonstrate the Radar Clutter
5	Able to explain Doppler and Adaptive Array Processing

**Syllabus**

**Module 1: Radar Systems (an overview)**

Range Measurements, Range Resolution, Doppler Frequency, Coherence, The Radar Equation, Surveillance Radar Equation, Radar Cross Section, Radar Equation with Jamming, Noise Figure Effects of the Earth's Surface on the Radar Equation, Atmospheric Attenuation. [8]

**Module 2: Target Detection, Pulse Integration and Pulse Compression**

Target Detection in the Presence of Noise, Probability of False Alarm, Probability of Detection, Pulse Integration, Target Fluctuating, Probability of False Alarm Formulation for a Square Law Detector, Probability of Detection Calculation, Computation of the Fluctuation Loss, Cumulative Probability of Detection, Constant False Alarm Rate (CFAR), Time-Bandwidth Product, Radar Equation with Pulse Compression, Basic Principal of Pulse Compression, Correlation Processor, Stretch Processor. [8]

**Module 3: Matched Filter and Ambiguity Function**

The Matched Filter SNR, Mean and Variance of the Matched Filter Output, General Formula for the Output of the Matched Filter, Waveform Resolution and Ambiguity, Range and Doppler Uncertainty, Target Parameter Estimation, Examples of the Ambiguity Function, Stepped Frequency Waveforms, Nonlinear FM Ambiguity Diagram Contours, Interpretation of Range-Doppler Coupling in LFM Signals, Discrete Code Signal Representation, Pulse-Train Codes, Phase Coding, Frequency Codes, Ambiguity Plots for Discrete Coded Waveforms. [8]

**Module 4: Radar Clutter**

Clutter Cross Section Density, Surface Clutter, Volume Clutter, Clutter RCS, Clutter Spectrum, Moving Target Indicator (MTI), PRF Staggering, MTI Improvement Factor, Subclutter Visibility, Delay Line Cancelers with Optimal Weights. [8]

**Module 5:Doppler and Adaptive Array Processing**

CW Radar Functional Block Diagram, Pulsed Radars, Introduction to Adaptive Array Processing, General Arrays, Linear Arrays, Nonadaptive Beamforming, Adaptive Array Processing. [8]

**TEXTBOOKS:**

1. Bassem R. Mahafza, Radar Signal Analysis and Processing Using MATLAB, Chapman and Hall/CRC, 2008.

**REFERENCE BOOKS:**

1. M.I. Skolnik, “Introduction to Radar Systems”, 3/e, TMH, New Delhi, 2001
2. Nathanson, F. E., Radar Design Principles, New York, McGraw-Hill, 2<sup>nd</sup> Edition, 1991
3. Toomay, J. C., Radar Principles for the Non-Specialist, New York, Van Nostrand, Reinhold, 1989
4. Buderer R., The Invention That Changed the World, New York, Simon and Schuster, 1996
5. R.J Sullivan, Radar foundation for imaging & advanced concepts, PHI, 2004.
6. Mark A Richards, Fundamentals of Radar Signal Processing,McGraw -Hill Company, 2005

**COURSE OUTCOME (CO) ATTAINMENT ASSESSMENT TOOLS & EVALUATION PROCEDURE**

**DIRECT ASSESSMENT**

Assessment Tool	% Contribution during CO Assessment
Quizzes (3)	3x10 = 30
Seminar	10
Teacher’s Assessment	10
Semester End Examination	50

**INDIRECT ASSESSMENT –**

1. Students’ Feedback on Course Outcome

**MAPPING OF COURSE OUTCOMES ONTO PROGRAM OUTCOMES**

CO	PO1	PO2	PO3	PO4	PO5	PO6
CO1	2	2	3	3	2	-
CO2	2	2	3	3	2	-
CO3	2	2	3	3	2	-

CO4	2	2	3	3	2	-
CO5	2	2	3	3	2	-

Correlation Levels 1, 2 or 3 as defined below:

1: Slight (Low) 2: Moderate (Medium) 3: Substantial (High)

**Gaps in the syllabus (to meet Industry/Profession requirements):** Design of real-time industrial projects.

**POs met through Gaps in the Syllabus:** PO2

**Topics beyond syllabus/Advanced topics/Design:** Design of real-time industrial projects.

**POs met through Topics beyond syllabus/Advanced topics/Design:** PO5 & PO6

#### **Course Delivery Methods**

<b>CD</b>	<b>Course Delivery methods</b>
CD1	Lecture by use of boards/LCD projectors/OHP projectors
CD2	Assignments
CD3	Laboratory experiments/Teaching aids/Seminars
CD4	Mini Projects
CD5	Industrial visits/in-plant training
CD6	Self- learning such as use of NPTEL materials and internets
CD7	Simulation

#### **MAPPING BETWEEN COURSE OUTCOMES AND COURSE DELIVERY METHOD**

<b>Mapping Between COs and Course Delivery (CD) methods</b>	
<b>Course Outcomes</b>	<b>Course Delivery Method</b>
CO1	CD1, CD6, CD7
CO2	CD1, CD6, CD7
CO3	CD1, CD2, CD6, CD7
CO4	CD1, CD2, CD6, CD7
CO5	CD1, CD2, CD6, CD7

## **COURSE INFORMATION SHEET**

**Course code:** EC509

**Course title:** RF Microelectronics Circuit Design

**Pre-requisite(s):** EC201 Electronic Devices, EC253 Analog Circuits

**Co- requisite(s):**

**Credits: L: 3 T: 0 P: 0 C: 3**

**Class period per week: 03**

**Class: M. Tech.**

**Semester / Level: I/05**

**Branch: ECE**

**Name of Teacher:**

**Course Objectives:** This course enables the students to

A.	Understand RF frequency response of MOSFET.
B.	Grasp the RF Technology and basic concepts in RF design and apply the same.
C.	Appraise communication concepts and analyze transceiver architectures.
D.	Appraise and evaluate the basic blocks in RF systems such as LNA, Mixer and VCO and their VLSI implementations.
E.	Comprehend the characteristics of RF synthesizers and Power Amplifiers and create their circuits.

**Course Outcomes:**

After the completion of this course, a student will be able to:

1	Illustrate and Interpret RF frequency response of MOSFET.
2	Sketch and explain the RF technology and basic concepts in RF design.
3	Diagram and explain communication concepts in transceiver architectures.
4	Appraise the basic blocks in RF systems such as LNA, Mixer and VCO, schematize, assess and summarize their features.
5	Design and schematize basic blocks in RF systems such as RF Synthesizer and Power Amplifiers. Schematize their characteristics and prepare an inference.

## **Syllabus**

### **Module -1: RF frequency response of MOSFET**

Derivation and estimation of MOS capacitor, MOS capacitor in cutoff, linear and saturation region, derivation and estimation of MOSFET's long-channel model including threshold voltage, body effect, transconductance ( $g_m$ ), output conductance ( $g_{ds}$ ), small-signal output resistance ( $r_o$ ), A Medium-Frequency Small-Signal Model for the Intrinsic Part, Intrinsic Transition Frequency, Noise in MOSFET: white noise, flicker noise, High frequency Small-Signal Model, Transition Frequency ( $f_T$ ) and Maximum oscillation ( $f_{max}$ ) of MOSFET.

[8]

### **Module -2: RF technology and basic concepts in RF design**

Introduction to RF and Wireless Technology: Challenges in RF Design, Complexity Comparison, Design Bottleneck, Applications, Choice of Technology; Basic concepts in RF Design: Units in RF Design, Time Variance, Nonlinearity, Effects of nonlinearity; Noise as Random Process, effect of transfer function on noise, device Noise, Representation of Noise in Circuits. Sensitivity and Dynamic Range.

[8]

### **Module -3: Communication concepts and transceiver architectures**

Analog modulation, Digital modulation, Spectral Regrowth, Mobile RF Communications, Multiple Access techniques Wireless standards; Receiver Architectures: Basic Heterodyne Receivers, Modern Heterodyne Receivers, Direct-Conversion Receivers, Image Reject Receivers, Low-IF Receivers; Transmitter Architectures: Direct-Conversion Transmitters, Modern Direct-Conversion Transmitters, Heterodyne Transmitters. [8]

**Module -4: Basic blocks in RF systems and their VLSI implementation**

Low Noise Amplifier: General considerations, Problem of input matching, Basic LNA Topologies (Common-Source Stage with Inductive Load, Common-Source Stage with Resistive Feedback). Mixers: General Considerations, Active Down-conversion Mixers, Improved Mixer Topologies. Oscillators: Performance Parameters, Voltage-Controlled Oscillators (VCOs), LC VCOs with Wide Tuning Range, Basic concepts and effect of phase noise, Design procedure, LO Interface, Mathematical Model of VCOs, Basic concepts quadrature oscillators. [8]

**Module -5: Radio Frequency Synthesizer and Power Amplifiers**

Phase-locked loops: Basic concepts, Type-I PLLs, Type-II PLLs (Phase/Frequency detectors, Charge-pump PLLs). Radio Frequency Synthesizers: General considerations, Basic integer-N synthesizer, Basic concepts of fractional-N synthesizers. Power Amplifiers: General Considerations, Classification of Power Amplifiers, High-Efficiency Power Amplifiers. [8]

**TEXTBOOKS:**

1. John W. M. Rogers, Calvin Plett, Radio Frequency Integrated Circuit Design, Artech House, 2010.
2. Yannis Tsvividis, Colin McAndrew, Operation and Modeling of MOS Transistor, Oxford University Press, 3rd edition, 2011.
3. Behzad Razavi, RF Microelectronics, 2e, Prentice Hall, 2011.

**REFERENCE BOOKS:**

1. Samuel Y. Liao, Microwave Devices and Circuits, 3e, Prentice-Hall of India, 2003.
2. Paul R. Gray, Paul J. Hurst, Stephen H. Lewis and Roberst G. Meyer, Analysis and Design of Analog Integrated Circuits, 5/e, Wiley, 2009.
3. The Design of CMOS Radio-Frequency Integrated Circuits by Thomas H. Lee. Cambridge University Press, 2004.

**COURSE OUTCOME (CO) ATTAINMENT ASSESSMENT TOOLS & EVALUATION PROCEDURE**

**DIRECT ASSESSMENT**

Assessment Tool	% Contribution during CO Assessment
Quizzes (3)	3x10 = 30
Seminar	10
Teacher’s Assessment	10

Semester End Examination	50
--------------------------	----

**INDIRECT ASSESSMENT –**

1. Students’ Feedback on Course Outcome

**MAPPING OF COURSE OUTCOMES ONTO PROGRAM OUTCOMES**

CO	PO1	PO2	PO3	PO4	PO5	PO6
CO1	3	3	3	3	2	1
CO2	3	3	3	3	2	1
CO3	3	3	1	3	2	1
CO4	2	2	2	2	3	2
CO5	2	2	2	2	3	2

Correlation Levels 1, 2 or 3 as defined below:

- 1: Slight (Low) 2: Moderate (Medium) 3: Substantial (High)

**Gaps in the syllabus (to meet Industry/Profession requirements):** Hands-on-practical for RF IC (Radio Frequency Integrated Circuit) fabrication.

**POs met through Gaps in the Syllabus:** PO6 will be met though RF circuit design-based assignment, which involves handling of RF equipments and CAD tools.

**Topics beyond syllabus/Advanced topics/Design:** Microelectronic Circuit Designs related to Digital, Analog and Mixed-Signal (such as ADC and DAC).

**POs met through Topics beyond syllabus/Advanced topics/Design:** PO6

**Course Delivery Methods**

CD	Course Delivery methods
CD1	Lecture by use of boards/LCD projectors/OHP projectors
CD2	Assignments
CD3	Laboratory experiments/Teaching aids/Seminars
CD4	Mini Projects
CD5	Industrial visits/in-plant training
CD6	Self- learning such as use of NPTEL materials and internets
CD7	Simulation

**MAPPING BETWEEN COURSE OUTCOMES AND COURSE DELIVERY METHOD**

Mapping Between COs and Course Delivery (CD) methods	
Course Outcomes	Course Delivery Method

CO1	CD1, CD2, CD3, CD6
CO2	CD1, CD2, CD3, CD6, CD7
CO3	CD1, CD2, CD3, CD6, CD7
CO4	CD1, CD2, CD3, CD6, CD7
CO5	CD1, CD2, CD3, CD6, CD7

## PROGRAMME CORE

### COURSE INFORMATION SHEET

**Course code:** EC502

**Course title:** Microwave Measurement Lab

**Pre-requisite(s):** EC257 Electromagnetic Fields and Waves

**Co- requisite(s):**

**Credits:** L: 0 T: 0 P: 4 C: 2

**Class schedule per week:** 04

**Class:** M. Tech.

**Semester / Level:** I/05

**Branch:** ECE

**Name of Teacher:**

**Course Objectives:** This course enables the students to

A.	Develop the ability to analyze the propagation modes in free space and waveguide
B.	Develop the ability to analyze the performance parameters of microwave active devices
C.	Develop the ability to analyze the performance parameters of RF Mixer and Switch
D.	Develop an ability to analyze, measure and evaluate crosstalk, radiated and conducted emissions to examine the shielding effectiveness of conducting materials.
E.	Develop the ability to analyze the performance parameters of different types of Radars

**Course Outcomes:**

After the completion of this course, a student will be able to

1.	Understand the various propagation modes in free space and waveguide
2.	Measure and analyze the performance parameters of microwave active devices
3.	Measure and analyze the performance parameters of RF Mixer and Switch
4.	To analyze, measure and evaluate crosstalk, radiated and conducted emissions to examine the shielding effectiveness of conducting materials
5.	Measure and analyze the performance parameters of different types of Radars

**Syllabus**

**LIST OF EXPERIMENTS:**

1. Analysis of various propagation modes in free space.
2. Analysis of various propagation modes in waveguide.
3. Measurement of performance parameters of microwave amplifier
4. Measurement of performance parameters of microwave voltage-controlled oscillator
5. Measurement of performance parameters of RF mixer
6. Measurement of performance parameters of RF Switch
7. To study electrostatic discharge, different crosstalk in the cable and its reduction technique and to measure crosstalk in a three-conductor transmission line using VNA
8. To measure the conducted emission using LISN and radiated emission from mobile tower and mobile phone.
9. To measure the performance parameter of an EMI sensor and Shielding Effectiveness of conducting material.
10. To evaluate the performance of Doppler Radar
11. To evaluate the performance of MTI radar
12. To evaluate the performance of FM CW Radar

**TEXTBOOKS:**

1. David M. Pozar, "Microwave Engineering", Third Edition, Wiley India.
2. R. Ludwig and G. Bogdanov, "RF Circuit Design, Theory and Applications", Pearson, 2<sup>nd</sup> Edition.

**REFERENCE BOOKS:**

1. Paul, C., Introduction to Electromagnetic Compatibility, John Wiley & Sons, 1992.
2. M.I. Skolnik, "Introduction to Radar System", McGraw Hill 2<sup>nd</sup> Edition

**COURSE OUTCOME (CO) ATTAINMENT ASSESSMENT TOOLS AND EVALUATION PROCEDURE**

**DIRECT ASSESSMENT**

<b>Assessment Tools</b>	<b>% Contribution during CO Assessment</b>
Progressive Evaluation	60
End Semester Evaluation	40

<b>Progressive Evaluation</b>	<b>% Distribution</b>
Day to day performance & Lab files	30
Quiz (zes)	10
Viva	20

<b>End Semester Evaluation</b>	<b>% Distribution</b>
Examination Experiment Performance	30
Quiz	10

**INDIRECT ASSESSMENT –**

1. Students' Feedback on Course Outcome

**MAPPING OF COURSE OUTCOMES ONTO PROGRAM OUTCOMES**



CO	PO1	PO2	PO3	PO4	PO5	PO6
CO1	2	3	3	3	2	3
CO2	2	3	3	3	2	3
CO3	2	3	3	3	2	3
CO4	2	3	3	3	2	3
CO5	2	3	3	3	2	3

Correlation Levels 1, 2 or 3 as defined below:

1: Slight (Low) 2: Moderate (Medium) 3: Substantial (High)

**Gaps in the syllabus (to meet Industry/Profession requirements):**

**POs met through Gaps in the Syllabus:**

**Topics beyond syllabus/Advanced topics/Design:**

**POs met through Topics beyond syllabus/Advanced topics/Design:**

### Course Delivery Methods

CD	Course Delivery methods
CD1	Lecture by use of boards/LCD projectors/OHP projectors
CD2	Assignments
CD3	Laboratory experiments/Teaching aids/Seminars
CD4	Mini Projects
CD5	Industrial visits/in-plant training
CD6	Self- learning such as use of NPTEL materials and internets
CD7	Simulation

### MAPPING BETWEEN COURSE OUTCOMES AND COURSE DELIVERY METHOD

Mapping Between COs and Course Delivery (CD) methods	
Course Outcomes	Course Delivery Method
CO1	CD3, CD7
CO2	CD3, CD7
CO3	CD3, CD7
CO4	CD3, CD7

CO5	CD3, CD7
-----	----------

## COURSE INFORMATION SHEET

**Course code: EC504**

**Course title: Antenna Lab**

**Pre-requisite(s): EC257 Electromagnetic Fields and Waves, EC323 Microwave Theory & Techniques**

**Co- requisite(s):**

**Credits: L: 0 T: 0 P: 4 C: 2**

**Class schedule per week: 04**

**Class: M. Tech.**

**Semester / Level: I/05**

**Branch: ECE**

**Name of Teacher:**

**Course Objectives :** This course enables the students

:

A.	To understand important and fundamental antenna engineering parameters.
B.	To develop the basic skills to learn software and apply in the design of various antennas.
C.	To develop the basic skills necessary to measure antenna performance parameters.
D.	To apply the concepts learnt through theory
E.	Develop the ability to analyze the performance parameters of different types of antenna

### Course Outcomes

After the completion of this course, students will be able to:

1.	Have the ability to implement the theoretical knowledge and prepare the reports and present the results.
2.	Apply numerical modelling tools (software) to design antennas, with particular reference to low profile printed antennas.
3.	Have the ability to perform antenna measurements.
4.	Understand and visualize the radiation characteristics and its limitations and provide the environment friendly solutions in terms of antenna design.
5.	Have the ability to Practically verify different microwave antenna theories.

### Syllabus

#### LIST OF EXPERIMENTS

- Design of a rectangular microstrip patch antenna for operating frequency 1.88GHz with  $\epsilon_r = 4.4$ ,  $h=31$  mils with inset feed. (IE3D)
- Design of a rectangular microstrip patch antenna for operating frequency 1.88GHz with  $\epsilon_r = 4.4$ ,  $h=31$  mils with coaxial feed. (IE3D)

3. Design of a rectangular microstrip patch antenna for operating frequency 5 GHz with  $\epsilon_r = 3.2$ ,  $h=0.762\text{mm}$  & transformer coupled microstrip feed. (IE3D)
4. Design of a circular microstrip patch antenna for circular polarization with dual feed. Assume resonant frequency =2.78GHz,  $\epsilon_r = 2.33$ ,  $h=2.184\text{mm}$ ,  $\tan\delta=0.0012$ . (IE3D)
5. Design of a rectangular microstrip patch antenna for operating frequency 1.88GHz with  $\epsilon_r = 4.4$ ,  $h=31$  mils & inset feed. (HFSS)
6. Design of a rectangular microstrip patch antenna for operating frequency 1.88GHz with  $\epsilon_r = 4.4$ ,  $h=31$  mils & transformer coupled microstrip feed. (HFSS)
7. To plot the radiation pattern of a directional antenna.
8. To plot the radiation pattern of an omni-directional antenna.
9. To calculate the resonant frequency and estimate the VSWR of an antenna.
10. To prove inverse square law for any antenna.
11. Characterization of a linearly polarized and circularly polarized antenna.
12. The gain measurement of an antenna under test.

**TEXTBOOKS:**

1. Antenna Theory, Analysis and Design, 3/E, A. Balanis, John Wiley.
2. Antennas, J. D. Kraus, TMH
3. Wireless Communications, Principles and Practices, Rappaport, PHI

**REFERENCE BOOKS:**

1. Software Radio A Modern Approach to Radio Engineering, J. H. Reed, Pearson Education.
2. Wireless and Cellular Communications, William C. Y. Lee, McGraw-Hill.
3. Wireless Communications, Principles and Practices, Rappaport, PHI.

**Course Evaluation:** Progressive Evaluation and End-Sem. Evaluation

**COURSE OUTCOME (CO) ATTAINMENT ASSESSMENT TOOLS AND EVALUATION PROCEDURE**

**DIRECT ASSESSMENT**

Assessment Tools	% Contribution during CO Assessment
Progressive Evaluation	60
End Semester Evaluation	40

Progressive Evaluation	% Distribution
Day to day performance & Lab files	30
Quiz (zes)	10
Viva	20

<b>End Semester Evaluation</b>	<b>% Distribution</b>
Examination Experiment Performance	30
Quiz	10

### **INDIRECT ASSESSMENT –**

1. Students' Feedback on Course Outcome

### **MAPPING OF COURSE OUTCOMES ONTO PROGRAM OUTCOMES**

<b>CO</b>	<b>PO1</b>	<b>PO2</b>	<b>PO3</b>	<b>PO4</b>	<b>PO5</b>	<b>PO6</b>
CO1	2	3	3	3	2	3
CO2	2	3	3	3	2	3
CO3	2	3	3	3	2	3
CO4	2	3	3	3	2	3
CO5	2	3	3	3	2	3

Correlation Levels 1, 2 or 3 as defined below:

1: Slight (Low) 2: Moderate (Medium) 3: Substantial (High)

**Gaps in the syllabus (to meet Industry/Profession requirements):**

**POs met through Gaps in the Syllabus:**

**Topics beyond syllabus/Advanced topics/Design:**

**POs met through Topics beyond syllabus/Advanced topics/Design:**

### **Course Delivery Methods**

<b>CD</b>	<b>Course Delivery methods</b>
CD1	Lecture by use of boards/LCD projectors/OHP projectors
CD2	Assignments
CD3	Laboratory experiments/Teaching aids/Seminars
CD4	Mini Projects
CD5	Industrial visits/in-plant training
CD6	Self- learning such as use of NPTEL materials and internets
CD7	Simulation

**MAPPING BETWEEN COURSE OUTCOMES AND COURSE DELIVERY METHOD**

<b>Mapping Between COs and Course Delivery (CD) methods</b>	
<b>Course Outcomes</b>	<b>Course Delivery Method</b>
CO1	CD1, CD3
CO2	CD3
CO3	CD5, CD3
CO4	CD5, CD3, CD7
CO5	CD3, CD7

## **SECOND SEMESTER**

### **PROGRAMME CORE**

### **COURSE INFORMATION SHEET**

**Course code:** EC550

**Course title:** Microwave & Mm-wave Integrated Circuits and Applications

**Pre-requisite(s):** EC323 Microwave Theory & Technique

**Co- requisite(s):**

**Credits:** L:3 T:0 P:0 C:3

**Class schedule per week:** 03

**Class:** M. Tech. Microwave Engg

**Semester / Level:** II/05

**Branch:** ECE

**Name of Teacher:**

**Course Objectives :** This course enables the students

A.	State the concept of MMIC and MM-wave technology along with their fabrication techniques
B.	Comprehensive knowledge of the passive circuit elements for microwave and MM-wave technology.
C.	Illustrate basic of active elements for microwave and MM-wave technology.
D.	Enhance skills of different measurement techniques for microwave and MM-wave technology.
E.	Design systems and its application for microwave and MM-wave technology.

#### **Course Outcomes**

After the completion of this course, students will be:

<b>1</b>	Able to explain the requirement of MMIC and MM-wave technologies and their fabrication techniques.
<b>2</b>	Able to analyse passive circuit elements for microwave and MM-wave technology.
<b>3</b>	Able to analyze the active elements for microwave and MM-wave technology.
<b>4</b>	Examine different measurement techniques for microwave and MM-wave technology.
<b>5</b>	Aspire for pursuing a carrier in system application for microwave and MM-wave technology.

### **Module 1: Introduction to Monolithic Microwave Integrated Circuit**

(MMICs) technology, different types of MMIC, Advantages, disadvantages and application of MMICs, MMIC fabrication techniques, Thick and Thin film technologies and materials, Encapsulation and mounting of active devices, Introduction to MM-Wave Integrated Circuits, GaAs Fabrication Technology and various processes, Materials used for MM-wave Integrated Guides. [11]

### **Module 2: Passive Circuit elements**

Transmission lines for Microwave Integrated Circuits, Discontinuities, Lumped elements  
Passive Components: Introduction, Power transfer in parallel-coupled guides, Parallel Guide Directional Couplers, Other Directional Couplers, Ring Resonator Filters [6]

### **Module 3: Active Semiconductor circuit elements**

Schottky-barrier diodes, Varactor diodes, p-i-n diodes, Bipolar Transistors, MESFETs, HEMTs Active Components: Introduction, Image Guide Detector Circuits, Oscillators, Electronic Phase Shifters, Balanced Mixers, Amplifiers, High Frequency Devices, Low Noise MM-wave Amplifier and Monolithic Mixers. [11]

### **Module 4: Measurement Techniques**

Introduction, Test fixture measurements, Probe station measurements, Thermal and cryogenic measurements, Experimental field probing techniques, MM-wave measurement techniques: Electric field probe, Measurement of Attenuation constant and guide wavelength. Measurement at Radiation Loss at bends. [6]

### **Module 5: System Application:**

MICs in Phased Array Radars, MICs in Satellite Television Systems, Microwave Radio Systems, Monolithic MM-wave Transceiver [6]

### **TEXT BOOKS:**

1. MMIC Design by I. D. Robertson, The Institution of Electrical Engineers, U.K., 1995
2. Microwave Integrated circuit by K. C. Gupta, A. Singh, John Wiley & Sons, 1974
3. Millimeter wave Integrated Circuit by E. Carey and S. Lidholm, Springer, 2005
4. Millimeter Wave and Optical Dielectric Integrated Guides and Circuits by S. K. Koul, John Wiley & Sons, 1997.
5. Microwave Integrated Circuits by I. Kneppo, J. Fabian, P. Bezousek, P. Hrnicko and M. Pavel, Springer.

### **REFERENCE BOOKS:**

1. Strip-line-like Transmission lines for Microwave Integrated circuits, B. Bhat, S. K. Koul, Wiley Eastern Ltd., New Delhi.

### **COURSE OUTCOME (CO) ATTAINMENT ASSESSMENT TOOLS & EVALUATION PROCEDURE**

## DIRECT ASSESSMENT

Assessment Tool	% Contribution during CO Assessment
Quizzes (3)	3x10 = 30
Seminar	10
Teacher's Assessment	10
Semester End Examination	50

## INDIRECT ASSESSMENT –

1. Students' Feedback on Course Outcome

## MAPPING BETWEEN COURSE OUTCOMES AND PROGRAM OUTCOMES

CO	PO1	PO2	PO3	PO4	PO5	PO6
CO1	2	2	3	3	1	2
CO2	2	2	3	3	2	1
CO3	2	2	3	3	2	1
CO4	2	2	3	3	2	3
CO5	2	2	3	3	2	2

Correlation Levels 1, 2 or 3 as defined below:

- 1: Slight (Low) 2: Moderate (Medium) 3: Substantial (High)

### Gaps in the syllabus (to meet Industry/Profession requirements):

Hands on experience on solution of Real time Industrial Project and management.

### POs met through Gaps in the Syllabus: PO5, PO6

**Topics beyond syllabus/Advanced topics/Design:** Microwave and mm-Wave Microelectronics, High-power broadband solid state isolators, Broadband, outphasing, multi-way power amplifiers on-chip  
POs met through Topics beyond syllabus/Advanced topics/Design: **PO5 & PO6**

### Course Delivery Methods

CD	Course Delivery methods
CD1	Lecture by use of boards/LCD projectors/OHP projectors
CD2	Assignments
CD3	Laboratory experiments/teaching aids/Seminars
CD4	Mini Project
CD5	Industrial visits/in-plant training



CD6	Self- learning such as use of NPTEL materials and internets
CD7	Simulation

**MAPPING BETWEEN COURSE OUTCOMES AND COURSE DELIVERY METHOD**

<b>Mapping Between COs and Course Delivery (CD) methods</b>	
Course Outcomes	Course Delivery Method
CO1	CD1, CD2, CD6
CO2	CD1, CD2, CD3, CD6, CD7
CO3	CD1, CD2, CD3, CD6, CD7
CO4	CD1, CD2, CD3
CO5	CD1, CD2

**COURSE INFORMATION SHEET**

**Course code: EC551**

**Course title: RF Circuit Design**

**Pre-requisite(s): EC257 Electromagnetic Fields and Waves, EC323 Microwave Theory & Technique**

**Co- requisite(s):**

**Credits: L:3 T:0 P:0 C:3**

**Class schedule per week: 03**

**Class: M. Tech. Microwave Engg**

**Semester / Level: II/05**

**Branch: ECE**

**Name of Teacher: .....**

**Course Objectives :** This course enables the students

A.	To explain radio frequency design concept and impart knowledge on design and implementation of high frequency transceiver system.
B.	To develop an ability to analyze various components of radio frequency communication system architecture.
C.	To develop an ability to analyze the impact of different design parameters in transceiver circuit design, besides developing an insight to make use of several high frequency design techniques.
D.	To develop the prototype models of the various RF circuit components.
E.	To review and refer the literature related to RF Circuit design and report it ethically.

**Course Outcomes**

After the completion of this course, students will be:

1.	Able to explain radio frequency design concept and impart knowledge on design and implementation of high frequency transceiver system.
----	--

2.	Able to develop an ability to analyze various components of radio frequency communication system architecture.
3.	Able to develop an ability to analyze the impact of different design parameters in transceiver circuit design, besides developing an insight to make use of several high frequency design techniques.
4.	Able to develop the prototype models of the various RF circuit components.
5.	Able to review and refer the literature related to RF Circuit design and report it ethically.

## Syllabus

### **Module 1: Introduction:**

Importance of RF Design, RF Behavior of Passive Components: High Frequency Resistors, High-Frequency Capacitors, High-Frequency Inductors. Chip Components and Circuit Board Considerations: Chip Resistors, Chip Capacitors, Surface-Mounted Inductors.

[6]

### **Module 2: RF Filter Design**

Basic Resonator and Filter Configurations: Filter Type and Parameters, Low-Pass Filter, High Pass Filter, Bandpass and Bandstop Filters, Insertion Loss, Special Filter Realizations: Butterworth –Type, Chebyshev and Denormalization of Standard Low-Pass Design. Filter Implementations: Unit Elements, Kuroda’s Identities and Examples of Microstrip Filter Design. Coupled Filter: Odd and Even Mode Excitation, Bandpass Filter Section, Cascading Bandpass Filter Elements, Design Examples.

[10]

### **Module 3: Matching and Biasing Network**

Impedance Matching using Discrete Components: Two Component Matching Networks, Forbidden regions, Frequency Response and Quality Factor, Microstrip Line Matching Networks: From Discrete Components to Microstrip Lines, Single-Stub Matching Networks, Double-Stub Matching Networks, Amplifier Classes of Operation and Biasing Network: Classes of Operation and Efficiency of Amplifiers, Bipolar Transistor Biasing Networks, Field Effect Transistor Biasing Networks.

[8]

### **Module 4: RF Transistor Amplifier Design**

Characteristics of Amplifiers, Amplifier Power Relations: RF source, Transducer Power Gain, Additional Power Relations, Stability Considerations: Stability Circles, Unconditional Stability, Stabilization Methods, Constant Gain: Unilateral Design, Unilateral Figure of Merit, Bilateral Design, Operating and Available Power Gain Circles. Noise Figure Circles, Constant VSWR Circles. Broadband, High Power and Multistage Amplifiers.

[8]

### **Module 5: RF Oscillators and Mixers**

Basic Oscillator Model: Negative Resistance Oscillator, Feedback Oscillator Design, Design Steps, Quartz Oscillators. High Frequency Oscillator Configuration: Fixed Frequency Oscillators, Dielectric Resonator Oscillators, YIG-Tuned Oscillators, Voltage Controlled Oscillators, Gunn Element Oscillator. Basic Characteristics of Mixers: Basic Concepts, Frequency Domain Considerations, Single-Balanced Mixer Double-Balanced Mixer. [8]

**TEXT BOOKS:**

1. RF Circuit Design Theory and Application, Reinhold Ludwig and Pavel Bretchko, Ed. 2004, Pearson Education.

**REFERENCE BOOKS:**

1. Microstrip Filters for RF/Microwave Applications, Jia-Sheng Hong, M. J. Lancaster, John Wiley & Sons, 2001.

**COURSE OUTCOME (CO) ATTAINMENT ASSESSMENT TOOLS & EVALUATION PROCEDURE**

**DIRECT ASSESSMENT**

Assessment Tool	% Contribution during CO Assessment
Quizzes (3)	3x10 = 30
Seminar	10
Teacher’s Assessment	10
Semester End Examination	50

**INDIRECT ASSESSMENT –**

1. Students’ Feedback on Course Outcome

**MAPPING BETWEEN COURSE OUTCOMES AND PROGRAM OUTCOMES**

CO	PO1	PO2	PO3	PO4	PO5	PO6
CO1	1	1	1	2	2	1
CO2	2	1	2	2	2	1
CO3	2	1	2	2	2	1
CO4	3	1	3	3	3	1
CO5	1	3	1	1	1	1

Correlation Levels 1, 2 or 3 as defined below:

1: Slight (Low) 2: Moderate (Medium) 3: Substantial (High)

**Gaps in the syllabus (to meet Industry/Profession requirements) :**Hands on experience on real-time

industrial projects and management.

POs met through Gaps in the Syllabus: **PO5 & PO6**

**Topics beyond syllabus/Advanced topics/Design:**

Design of Millimeter wave circuits and components.

POs met through Topics beyond syllabus/Advanced topics/Design: **PO5 & PO6**

**Course Delivery Methods**

<b>CD</b>	<b>Course Delivery methods</b>
CD1	Lecture by use of boards/LCD projectors/OHP projectors
CD2	Assignments
CD3	Seminar
CD4	Mini projects
CD5	Laboratory experiments/teaching aids
CD6	Self- learning such as use of NPTEL materials and internets
CD7	Simulation

**MAPPING BETWEEN COURSE OUTCOMES AND COURSE DELIVERY METHOD**

<b>Mapping Between COs and Course Delivery (CD) methods</b>	
<b>Course Outcomes</b>	<b>Course Delivery Method</b>
CO1	CD1,CD6
CO2	CD1, CD6,CD7
CO3	CD1, CD2, CD3,CD6,CD7
CO4	CD1, CD3,CD6,CD7
CO5	CD1,CD2,CD3,CD4,CD7

**COURSE INFORMATION SHEET**

**Course code:** EC553

**Course title:** Numerical Techniques in Electromagnetics

**Pre-requisite(s):** EC257 Electromagnetic Fields and Waves

**Co- requisite(s):**Computational Electromagnetics Lab.

**Credits:** L: 3 T:0 P:0 C: 3

**Class schedule per week:**03

**Class:** M. Tech.Microwave Engg

**Semester / Level:** II/05

**Branch** ECE

**Name of Teacher:**

**Course Objectives :**This course enables the students

A.	To understand the need of numerical techniques and classification of
----	--

	EM problems
B.	To study the various numerical techniques used in analyzing EM problems
C.	To solve simple EM problems using numerical techniques

### Course Outcomes

After the completion of this course, students will be able:

1.	To classify the EM problems.
2.	To acquire theoretical knowledge and explain various numerical methods of electromagnetics.
3.	To formulate real life problem to mathematical model.
4.	To apply various deterministic numerical methods to different static, scattering and radiation problems
5.	To apply non-deterministic numerical methods to different static, scattering and radiation problems

### Syllabus

#### **Module -1: Introduction**

Need for Numerical Solution of Electromagnetic problems, Selection of a numerical method, Classification of Electromagnetic problems, Classification of Solution Region, Classification of Boundary Conditions.

[7]

#### **Module -2: Finite Difference (FD) and Finite Difference Time Domain (FDTD Methods**

Introduction, FD schemes for parabolic, hyperbolic & Elliptical partial differential equations, solving the Laplace, diffusion and wave equations by FD method. Application to Guided structures: microstrip line and rectangular waveguide. Yee's FD algorithms, Accuracy & stability, Lattice truncation condition, Initial fields. Absorbing Boundary conditions for FDTD, Scattering problems.

[9]

#### **Module -3: Integral Equations and Method of Moments (MoM)**

Classification of Integral Equations, Relation between Differential and Integral Equations, Green's function: definition, Green's function for free space, Solution of integral equations using MoM, Quasi-static problems (thin conducting wire, parallel plate capacitor), Dipole antenna current distribution & input impedance, mutual impedance of two short dipoles, Scattering from a dipole antenna.

[8]

#### **Module -4 : Finite Element Method**

Finite Element Discretization, Element Governing Equations, Assembling of all Elements, Solving the resulting equations, Typical Applications.

[9]

**Module -5: Monte Carlo (MC) methods**

Introduction, Fixed and Floating Random Walks, Markov Chains, Solving typical electromagnetic Problems with random walk and Markov chain methods.

[7]

**TEXT BOOKS:**

1.Numerical Techniques in Electromagnetics Mathew N. O. Sadiku (CRC Press)

**REFERENCE BOOKS:**

1.Analytical and Computational Methods in Electromagnetics, Ramesh Garg, Artech House, 2008.

**COURSE OUTCOME (CO) ATTAINMENT ASSESSMENT TOOLS & EVALUATION PROCEDURE**

**DIRECT ASSESSMENT**

Assessment Tool	% Contribution during CO Assessment
Quizzes (3)	3x10 = 30
Seminar	10
Teacher’s Assessment	10
Semester End Examination	50

**INDIRECT ASSESSMENT –**

1. Students’ Feedback on Course Outcome

**MAPPING BETWEEN COURSE OUTCOMES AND PROGRAM OUTCOMES**

CO	PO1	PO2	PO3	PO4	PO5	PO6
CO1	2	1	2	3	2	1
CO2	2	1	3	3	2	2
CO3	2	2	3	3	3	3
CO4	3	2	3	3	3	3
CO5	3	2	3	3	3	3

Correlation Levels 1, 2 or 3 as defined below:

1: Slight (Low) 2: Moderate (Medium) 3: Substantial (High)

**Gaps in the syllabus (to meet Industry/Profession requirements):** Hands on experience on real-time industrial projects and management.

**POs met through Gaps in the Syllabus:** NIL

**Topics beyond syllabus/Advanced topics/Design:** Advanced Numerical and Theoretical Methods for Photonic Crystals and Metamaterials.

**POs met through Topics beyond syllabus/Advanced topics/Design:** PO5 & PO6

### Course Delivery Methods

CD	Course Delivery methods
CD1	Lecture by use of boards/LCD projectors/OHP projectors
CD2	Assignments
CD3	Seminar
CD4	Mini projects
CD5	Laboratory experiments/teaching aids
CD6	Self- learning such as use of NPTEL materials and internets
CD7	Simulation

MAPPING BETWEEN COURSE OUTCOMES AND COURSE DELIVERY METHOD	
Mapping Between COs and Course Delivery (CD) methods	
Course Outcome	Course Delivery Method
CO1	CD1, CD2, CD6
CO2	CD1, CD2, CD6
CO3	CD1, CD2, CD3, CD4, CD6
CO4	CD1, CD2, CD3, CD4, CD6, CD7
CO5	CD1, CD2, CD3, CD4, CD6, CD7

## PROGRAMME ELECTIVES-II COURSE INFORMATION SHEET

**Course code:** EC555  
**Course title:** Advanced Array Synthesis  
**Pre-requisite(s):** EC325 Antenna and Wave Propagation  
**Co-requisite(s):**  
**Credits:** L: 3 T: 0 P: 0 C:3  
**Class schedule per week:** 03  
**Class:** M. Tech. Microwave Engineering  
**Semester / Level:** II/05  
**Branch:** ECE

**Name of Teacher:**

**Course Objectives:** This course enables the students

A.	To appraise an overview of antennas and antenna Array
B.	To perceive the arrays such as linear, planar, 3D and conformal
C.	To analyze pattern synthesis techniques for arrays
D.	To grasp the various orthogonal synthesis methods for linear, non-linear and 3D arrays
E.	To understand the orama program computer tool

**Course Outcomes:**

After the completion of this course, students will be:

1.	Able to explain the concept of Antennas and Antenna Array.
2.	Able to explain the Arrays such as linear, planar, 3D. Conformal and Pattern Synthesis for Arrays
3.	Able to use pattern synthesis techniques for different types of arrays
4.	Able to analyse the orthogonal Synthesis Methods for linear, non-linear and 3D arrays
5.	Able to demonstrate the orama program computer tool

### **Syllabus**

#### **Module 1: Antennas and Antenna Array:**

Introduction, Antenna Array Factor, Elements and Array Types, Antenna Parameters and Indices, Antenna Input Impedance, Antenna Arrays Classification, Array Factor Classification. [6]

#### **Module 2: Arrays: Linear, Planar, 3D and Conformal:**

Introduction, Linear Arrays, Uniform Linear Arrays, Chebyshev Linear Arrays, Linear Arrays from Sampling or Root Matching of Line Sources, Planar Arrays, 3-D Arrays, Conformal Arrays. [8]

#### **Module 3: Pattern Synthesis for Arrays:**

Introduction, Uniform Linear Array Synthesis, Chebyshev Array Synthesis, Synthesis by Sampling or by Root Matching, Synthesis by Fourier Transform, The Woodward - Lawson (WL) Method, Array Synthesis as an Optimization Problem, Synthesis by Convolution of Linear, Planar and 3-D Arrays. [10]

#### **Module 4: The Orthogonal Methods:**

Introduction, Synthesis of Non-uniformly Spaced Linear Arrays: The Matrix Inversion Method, Synthesis of Non-uniformly Spaced Linear Arrays: The Orthogonal Method, Quantized Excitation and Geometry Synthesis of a Linear Array: The Orthogonal Perturbation Method, Synthesis of Non-uniformly Spaced Planar Arrays: The Orthogonal Method, Synthesis of Non-uniformly Spaced 3-D Arrays: The Orthogonal Method, Synthesis of Non-uniformly Spaced 3-D Arrays with Arbitrarily Oriented Dipoles: The Non-parallel Orthogonal Method, Synthesis of Arrays of Wire Antennas: The MoM Orthogonal Method, Synthesis of General Antenna Arrays:



The Orthogonal Compensation Method, Synthesis of Conformal Arrays: The Conformal Orthogonal Method. [10]

**Module 5: The Orama Computer Tool:**

Introduction, Description of the ORAMA Program, Element Types, Design Examples. [06]

**TEXT BOOKS:**

1. John Sahalos “Orthogonal Methods for Array Synthesis: Theory and the ORAMA Computer Tool” Wiley 2006

**REFERENCE BOOKS:**

1. Arun K. Bhattacharyya “Phased Array Antennas: Floquet Analysis, Synthesis, BFNs and Active Array Systems” Wiley 2006
2. Robert Mailloux “Electronically Scanned Arrays”, Morgan and Claypool Publication
3. Jeffrey D Connor “Antenna Array Synthesis Using the Cross Entropy Method” Proquest 2011

**COURSE OUTCOME (CO) ATTAINMENT ASSESSMENT TOOLS & EVALUATION PROCEDURE**

**DIRECT ASSESSMENT**

Assessment Tool	% Contribution during CO Assessment
Quizzes (3)	3x10 = 30
Seminar	10
Teacher’s Assessment	10
Semester End Examination	50

**INDIRECT ASSESSMENT –**

1. Students’ Feedback on Course Outcome

**MAPPING BETWEEN COURSE OUTCOMES AND PROGRAM OUTCOMES**

CO	PO1	PO2	PO3	PO4	PO5	PO6
CO1	1	1	2	3	2	1
CO2	1	1	2	3	3	2
CO3	2	2	2	3	3	2
CO4	2	3	3	3	3	3
CO5	3	3	3	3	3	3

Correlation Levels 1, 2 or 3 as defined below:

1: Slight (Low) 2: Moderate (Medium) 3: Substantial (High)

**Gaps in the syllabus (to meet Industry/Profession requirements):**

Hands on experience on real-time industrial projects and management.

**POs met through Gaps in the Syllabus:** PO5 & PO6

**Topics beyond syllabus/Advanced topics/Design:**

Evaluation and mixed optimization Algorithm, Internal Synthesis problem beam-forming networks

**Course Delivery Methods**

CD	Course Delivery methods
CD1	Lecture by use of boards/LCD projectors/OHP projectors
CD2	Assignments
CD3	Seminar
CD4	Mini projects
CD5	Laboratory experiments/teaching aids
CD6	Self- learning such as use of NPTEL materials and internets
CD7	Simulation

MAPPING BETWEEN COURSE OUTCOMES AND COURSE DELIVERY METHOD	
Mapping Between COs and Course Delivery (CD) methods	
Course Outcome	Course Delivery Method
CO1	CD1, CD2, CD6
CO2	CD1, CD2, CD3, CD6
CO3	CD1, CD2, CD3, CD4, CD6
CO4	CD1, CD2, CD3, CD4, CD6
CO5	CD1, CD2, CD3, CD4, CD6

**COURSE INFORMATION SHEET**

**Course code:** EC556

**Course title:** RF Micro-Electro-Mechanical-Systems

**Pre-requisite(s):** EE101 Basic Electrical, ME101 Basic Mechanical, EC323 Microwave Theory & Techniques

**Co-requisite(s):**

**Credits:** L: 3 T: 0 P: 0 C:3

**Class schedule per week:** 03

**Class:** M. Tech.

**Semester / Level:** II/05

**Branch:** ECE

**Name of Teacher:**

**Course Objectives:** This course enables the students

A.	Understand the basics of MEMS and RF MEMS
B.	Identify MEMS devices for a given application & Classification the different microfabrication process, microsensors, micro actuators and compare them
C.	Design micro machined passive components
D.	Analyze reliability issues in MEMS structures to introduce the students various opportunities in the emerging field of MEMS
E.	To develop an inclination towards electronics system design and manufacturing& their applications in different areas

### Course Outcomes:

After the completion of this course, students will be:

1	Identify various RF for MEMS devices, materials their parameters and packaging standards
2	Formulate fabrication steps and deposition techniques for MEMS devices
3	Develop the concept of Mechanical and electrical analogy, simulation of MEMS devices and modelling, Transmission lines
4	Analyze the reliability and design issues in MEMS structures and learn about RF MEMS Filters and RF MEMS Phase Shifters
5	Simulate micro machined passive components such as Inductors, Capacitors, Switches, and Antennas and evaluate the performance

### Syllabus

#### **Module 1: Introduction to MEMS**

General concepts on miniaturization and Radio frequency MEMS, Need for RF MEMS components in communications, space and defence applications Micro fabrications for MEMS Electromechanical transducers, Micro sensing for MEMS, Materials for MEMS and fabrication techniques, Thin films for MEMS and their deposition Techniques, Polymer MEMS, Silicon based MEMS, MEMS packaging.

[8]

#### **Module 2: RF transmission lines**

Theory, high frequency effects Sections of transmission lines Transmission line examples: microstrip, CPW. S-parameter theory Micro machined Transmission lines, Losses in transmission lines, Micro shield and membrane supported Transmission lines.

[8]

#### **Module 3: Micro machined RF filter**

Micro Mechanical filters, Surface Acoustic wave filter, Bulk Acoustic Wave, Micro machined filter for mm wave frequencies, Micro machined Phase shifter, Types of phase shifter and limitations, MEMS phase shifter, Ferroelectric phase shifters and applications.

[8]

#### Module 4: RF MEMS Switches and Micro Relays

Basic design guidelines Switch parameters, Switches for RF and microwave Applications, Actuation Mechanism for MEMS Switches, Dynamics of the switch operation, MEMS switch design and modelling Micro machined MEMS Inductors, modelling and design issues of planar inductors, MEMS Capacitors. [8]

#### Module 5: Micro machined Antenna

Basic characteristics and Design parameter of antenna, Micromachining techniques to improve antenna performance, Fabrication process of small antenna, Reconfigurable antenna. [8]

#### TEXTBOOKS:

1. RF MEMS and Their Applications by Vijay K.Varadan ,K.J.Vinoy,K.A.Jose Wiley India Ltd,2011 ISBN -978-81-265-2991-9.
2. RF MEMS Theory, Design and Technology by Gaberiel M.Rebiz, John Wiley & Sons,2003. ISBN-13: 978-0471201694, ISBN-10: 0471201693
3. Fundamentals of Microfabrication by Marc Madou, CRC Press, 1997.Gregory Kovacs,

#### REFERENCE BOOK:

1. Introduction to Microelectromechanical (MEM) Microwave Systems, H.J. De Los Santos, Artech house, 1999.
2. RF MEMS Circuit Design for Wireless Communications, H.J. De Los Santos, Artech House, 2003.
3. Microwave Engineering 2<sup>nd</sup> ed D.M. Pozar, John Wiley 2003
4. RF and Microwave Coupled-Line Circuits R. Mongia, I.J. Bahl, and P. Bhartia Artech House, 1999.

#### COURSE OUTCOME (CO) ATTAINMENT ASSESSMENT TOOLS & EVALUATION PROCEDURE

##### DIRECT ASSESSMENT

Assessment Tool	% Contribution during CO Assessment
Quizzes (3)	3x10 = 30
Seminar	10
Teacher's Assessment	10
Semester End Examination	50

##### INDIRECT ASSESSMENT –

1. Students' Feedback on Course Outcome

## MAPPING BETWEEN COURSE OUTCOMES AND PROGRAM OUTCOMES

CO	PO1	PO2	PO3	PO4	PO5	PO6
CO1	3	-	1	2	1	1
CO2	3	1	1	3	2	1
CO3	3	1	2	3	2	1
CO4	3	2	2	3	2	2
CO5	3	2	3	3	3	3

Correlation Levels 1, 2 or 3 as defined below:

1: Slight (Low) 2: Moderate (Medium) 3: Substantial (High)

### Gaps in the syllabus (to meet Industry/Profession requirements):

Design and Development of real-time industrial projects.

POs met through Gaps in the Syllabus: **PO4 & PO5**

### Topics beyond syllabus/Advanced topics/Design:

Micromechanical Signal Processors, Optical MEMS. Micro/Nano Fabrication, Micro-robotics. Wireless Sensor Networks, sensor interfaces, computation

POs met through Topics beyond syllabus/Advanced topics/Design: **PO4, PO5, PO6**

### **Course Delivery Methods**

CD	Course Delivery methods
CD1	Lecture by use of boards/LCD projectors/OHP projectors
CD2	Assignments
CD3	Seminar
CD4	Mini projects
CD5	Laboratory experiments/teaching aids
CD6	Self- learning such as use of NPTEL materials and internets
CD7	Simulation

## MAPPING BETWEEN COURSE OUTCOMES AND COURSE DELIVERY METHOD

Course Outcomes	Course Delivery Method
CO1	CD1, CD3, CD6
CO2	CD1, CD2, CD3, CD6, CD7
CO3	CD1, CD2, CD3, CD4, CD6, CD7

CO4	CD1, CD3, CD6, CD7
CO5	CD1,CD2,CD3,CD4,CD5,CD7

## COURSE INFORMATION SHEET

**Course code:** EC 557

**Course title:** Microwave Photonics

**Pre-requisite(s):** EC323 Microwave Theory & Techniques, EC425 Optoelectronics Devices

**Co-requisite(s):**

**Credits:** L: 3 T: 0 P: 0 C:3

**Class schedule per week:** 03

**Class:** M. Tech.

**Semester / Level:** II/05

**Branch:** ECE

**Name of Teacher:**

**Course Objectives:** This course enables the students

A.	To understand the basic concepts of microwave photonics
B.	To understand the characteristics of the components of microwave photonic system
C.	To understand the concepts of photonic processing of RF signal
D.	To understand the design aspects of microwave fibre optic link, and application of microwave photonics in sensing and imaging

### **Course Outcomes:**

After the completion of this course, students will be:

1.	To explain the key properties of microwave photonics
2.	To explain the key characteristics of microwave photonic components
3.	To explain the photonic processing of RF signal
4.	To design the microwave fiber optic link for RF over fiber
5.	To design the microwave photonics system for terahertz sensing and imaging applications

### **Syllabus**

#### **Module 1: Basic concepts of microwave photonics**

Microwave link architecture, E/O conversion, External modulation, O/E conversion, Photodetection, O/O components, Signal transport and signal generation, Signal processing, Radio over fibre.

[6]

#### **Module 2: Microwave photonics components**

Fast lasers sources, Tunable sources, Mode locked microchip lasers, Fast modulators, Electro-absorption modulators and photo-oscillators, High speed photodetectors, Travelling wave (TW) photodetector, GaAs MESFET Optical Detector, HBT phototransistor for optic/millimeter-wave converter.

[10]

### **Module 3: Microwave photonics signal processing (MWSP)**

Fundamental concepts and limitations, Optical sources of performance limitation, Electrical sources of performance limitation, Incoherent MWSP, Fibre delay line filters, Bragg grating delay line filter, Incoherent RF optical filter. **[8]**

### **Module 4: Microwave Fibre-Optic link design**

Requirements, Modulation techniques, Interfacing, Intrinsic link gain performance, Signal to noise performance, Link dynamic range, Fibre Radio systems, RF over fibre, IF over fibre, Baseband over fibre, WDM in fibre radio system, Optical Control of Phased Array antenna, Multi-Beam Photonic Array Feed antenna. **[8]**

### **Module 5: Terahertz sensing techniques**

Pulsed and Continuous wave system, Time domain spectroscopic system, Explosive identification, Terahertz imaging techniques, Passive and active imaging, CCD-based two-dimensional imaging, Space shuttle foam inspection, Tomography. **[8]**

#### **TEXTBOOKS:**

1. Stavros Iezekiel, "Microwave photonics: Devices and applications", IEEE Press, Willey,2009.
2. Anne Vilcot, Béatrice Cabon & Jean Chazelas, MICROWAVE PHOTONICS: From Components to Applications and Systems, Kluwer academic publishers.

#### **REFERENCE BOOK:**

1. Vincent J. Urick Jr, Jason D. McKinney, Keith J. Williams, Fundamentals of Microwave photonics, Willey Press.
2. Chi H. Lee, Microwave photonics, CRC Press
3. Anne Vilcot, MICROWAVE PHOTONICS: From Components to Applications and Systems, Kluwer academic publishers.

### **COURSE OUTCOME (CO) ATTAINMENT ASSESSMENT TOOLS & EVALUATION PROCEDURE**

#### **DIRECT ASSESSMENT**

<b>Assessment Tool</b>	<b>% Contribution during CO Assessment</b>
Quizzes (3)	3x10 = 30
Seminar	10
Teacher's Assessment	10

Semester End Examination	50
--------------------------	----

### INDIRECT ASSESSMENT –

1. Students' Feedback on Course Outcome

### MAPPING BETWEEN COURSE OUTCOMES AND PROGRAM OUTCOMES

CO	PO1	PO2	PO3	PO4	PO5	PO6
CO1	3	2	1	3	2	1
CO2	3	2	1	3	2	1
CO3	3	2	2	3	2	1
CO4	3	2	2	3	2	2
CO5	3	3	3	3	3	3

Correlation Levels 1, 2 or 3 as defined below:

1: Slight (Low) 2: Moderate (Medium) 3: Substantial (High)

**Gaps in the syllabus (to meet Industry/Profession requirements):** By learning software and hardware used by the companies.

**POs met through Gaps in the Syllabus: PO4 & PO6**

**Topics beyond syllabus/Advanced topics/Design:** Millimetre wave photonics

**POs met through Topics beyond syllabus/Advanced topics/Design: PO4 & PO6**

### Course Delivery Methods

CD	Course Delivery methods
CD1	Lecture by use of boards/LCD projectors/OHP projectors
CD2	Assignments
CD3	Seminar
CD4	Mini projects
CD5	Laboratory experiments/teaching aids
CD6	Self- learning such as use of NPTEL materials and internets
CD7	Simulation

### MAPPING BETWEEN COURSE OUTCOMES AND COURSE DELIVERY METHOD

Course Outcomes	Course Delivery Method
CO1	CD1, CD6
CO2	CD1, CD6, CD7
CO3	CD1, CD2, CD3, CD6, CD7
CO4	CD1, CD3, CD6,CD7
CO5	CD1, CD2,CD3,CD4,CD7



## COURSE INFORMATION SHEET

**Course Code:** EC558

**Course Title:** Modern Optimization Techniques

**Pre-requisite(s):** EC251 probability and Random Processes

**Co-requisite(s):**

**Credits:** L:3 T:0 P:0 C: 3

**Class schedule per week:** 03

**class:** M. Tech (Instrumentation) / Microwave Engg

**Semester / Level:** II/05

**Branch:** ECE

Name of Teacher:

**Course Objectives:** This course enables the students to

A.	Gain understanding on optimization theory and its elements
B.	Demonstrate single variable optimization, linear programming, dynamic programming concepts and techniques.
C.	Demonstrate multivariable and constraint optimization concepts and techniques.
D.	Understand on advance single and multi-objective optimization techniques such as GA, PSO, Pareto front, NSGA
E.	Demonstrate an ability to apply the optimization techniques to various areas of Engineering and Science.

### Course Outcomes

On the completion of this course, the students will be able to:

1.	Develop an understanding to formulate an optimization problem and its characteristics.
2.	Have an ability to analyse and formulate algorithms for design optimization.
3.	Apply optimum solutions employing the single objective evolutionary techniques for engineering applications.
4.	Apply optimum solutions employing the multi objective evolutionary techniques for engineering applications.

5.	Develop an ability to use the optimization techniques to communication, medical applications, control, power, mechanical problems, chemical, biology, finance and economics.
----	--

## **Syllabus**

### **Module 1: Basics of Optimization**

Optimal problem formulation, Design variables constraints, Objective function, Variable bounds, Search methods: optimality Criteria, Bracketing methods: Exhaustive search methods, Region – Elimination methods; Interval halving method, Fibonacci search method, Golden section search method, Point-estimation method; Successive quadratic estimation method. [8]

### **Module 2: Classical Optimization Methods-I**

Gradient-based methods: Newton-Raphson method, Bisection method, Secant method, Cauchy’s steepest descent and Newton’s method. Linear Programming: Graphical method, Simplex Method, Revised simplex method, Duality in Linear Programming (LP), integer linear programming, Dynamic programming, Sensitivity analysis. [8]

### **Module 3: Classical Optimization Methods-II**

Optimality criteria, Unidirectional search, Direct search methods: Simplex search method, Hooke-Jeeves pattern search method. Gradient based method, conjugate gradient method, concept of Lagrangian multiplier, complex search method, characteristics of a constrained problem. Direct methods: The complex method, Cutting plane method, Indirect method: Transformation Technique, Basic approach in the penalty function method, Interior penalty function method, convex method. [8]

### **Module 4: Single Objective Evolutionary Optimization Techniques**

Genetic algorithm and its working principle, GA variants, Particle swarm optimization and its working principle, Differential evolution, Ant Colony Optimization, Applications in Engineering problems. [7]

### **Module 5: Single Objective Evolutionary Optimization Techniques**

Multi objective Optimization problem, Dominance and Pareto-Optimality, Pareto front, Multi-objective Evolutionary Algorithms, Multi Objective genetic Algorithm, NSGA, Constrained Multi-objective Evolutionary Algorithms, Application to communication, medical, clustering, bioinformatics, control, finance. [8]

### **TEXTBOOKS:**

1. Optimization for Engineering Design - Kalyanmoy Deb, 2006, PHI
2. Kalyanmoy Deb, Multi-Objective Optimization using Evolutionary Algorithms, Wiley India publisher, 2010

3. S.S. Rao, Engineering Optimization, Theory and practice, New age International Publisher, 2012, D.E. Goldberg, genetic Algorithm in search, optimization and machine learning, Addison-Wesley Longman Publisher, 1989.

**REFERENCE BOOK:**

1. Analytical Decision Making in Engineering Design - Siddal.
2. G. Hadley, "Linear programming", Narosa Publishing House, New Delhi, 1990.

**COURSE OUTCOME (CO) ATTAINMENT ASSESSMENT TOOLS & EVALUATION PROCEDURE**

**DIRECT ASSESSMENT**

Assessment Tool	% Contribution during CO Assessment
Quizzes (3)	3x10 = 30
Seminar	10
Teacher's Assessment	10
Semester End Examination	50

**INDIRECT ASSESSMENT –**

1. Students' Feedback on Course Outcome

**MAPPING BETWEEN COURSE OUTCOMES AND PROGRAM OUTCOMES**

CO	PO1	PO2	PO3	PO4	PO5	PO6
CO1	3	1	2	2	-	2
CO2	3	2	2	3	-	1
CO3	3	2	2	3	1	1
CO4	3	3	2	3	1	2
CO5	-	1	1	1	-	2

Correlation Levels 1, 2 or 3 as defined below:

1: Slight (Low) 2: Moderate (Medium) 3: Substantial (High)

**Gaps in the Syllabus (to meet Industry/Profession requirements):**

Hands on experience on real time industrial projects and management,

POs met through gaps in the Syllabus: PO6

**Topics beyond Syllabus /Advanced topics/Design:** Hardware architecture design of optimization techniques

POs met through Topics beyond SYLLABUS/Advanced topics/Design: PO6

**Course Delivery Methods**

<b>CD</b>	<b>Course Delivery methods</b>
CD1	Lecture by use of boards/LCD projectors/OHP projectors
CD2	Assignments
CD3	Seminar
CD4	Mini projects
CD5	Laboratory experiments/teaching aids
CD6	Self- learning such as use of NPTEL materials and internets
CD7	Simulation

**MAPPING BETWEEN COURSE OUTCOMES AND COURSE DELIVERY METHOD**

<b>Course Outcomes</b>	<b>Course Delivery Method</b>
CO1	CD1, CD2, CD3, CD6
CO2	CD1, CD2, CD3, CD6, CD7
CO3	CD1, CD2, CD3, CD6, CD7
CO4	CD1, CD2, CD3, CD6, CD7
CO5	CD1, CD2, CD3, CD4

**COURSE INFORMATION SHEET**

**Course code: EC559**

**Course title: Mixed Signal VLSI Design**

**Pre-requisite(s):** EC253 Analog Circuits, EC203 Digital System Design

**Co- requisite(s):**

**Credits: L: 3 T: 0 P: 0 C: 3**

**Class schedule per week: 03**

**Class: M. Tech Instrumentation / Microwave Engg**

**Semester / Level: II/05**

**Branch: ECE**

**Name of Teacher:**

**Course Objectives:** This course enables the students to

A.	Understand the basics of sampling theory
B.	Apply the mixed-signal design trends and challenges
C.	Analyze the analog and discrete time filters
D.	Evaluate the different types of data converters
E.	Create frequency synthesizers and phased lock loop

**Course Outcomes:**

After the completion of this course, students will be able to:

1.	Describe and illustrate Analog and Discrete Time Signals
2.	Explain the mixed-signal design trends and challenges
3.	Analyze and illustrate analog and discrete time filters
4.	Design and appraise different types of data converters
5.	Design and schematize the frequency synthesizers and phased lock loop

## **Syllabus**

### **Module 1: Basics Sampling and Aliasing**

Analog and Discrete Time Signals and Systems, Analog and discrete-time signal processing, Sampling: Impulse Sampling, Decimation, The Sample-and-Hold (S/H), The Track-and-Hold (T/H), Interpolation, K-Path Sampling, Switched-Capacitor Circuits, Non-Overlapping Clock Generation, Circuits: Implementing the S/H, Finite Op-Amp Gain-Bandwidth Product, Autozeroing, Correlated Double Sampling (CDS), Selecting Capacitor Sizes, The S/H with Gain, Implementing Subtraction in the S/H, A Single-Ended to Differential Output S/H, The Discrete Analog Integrator (DAI), DAI Noise Performance, Fourier transform of continuous time and discrete-time signals, Laplace transform of analog signals, Z-transform of discrete-time signals.

## **Module 2: Mixed-Signal Design Trends and Challenges**

Design flow: Top-down design, Bottom-up Design, Constraint Management, Mixed-Signal Verification, Behavioral Modeling, Mixed-Signal Hardware Description Languages, Low Power Verification, Design for Test, Mixed-Signal layout & Chip Planning, Interconnects and data transmission, Substrate Noise, AMS IP Reuse, Full-chip Signoff, IC/Package Co-Design. [8]

## **Module 3: Analog and Digital Filters**

Analog Filters: Integrator Building Blocks: Lowpass Filters, Active-RC Integrators, Effects of Finite Op-Amp Gain Bandwidth Product, Active-RC SNR, MOSFET-C Integrators, gm-C (Transconductor-C) Integrators, Discrete-Time Integrators, Filtering Topologies: The Bilinear Transfer Function, The Biquadratic Transfer Function, *Digital Filters*: Sinc-Shaped Digital Filters: The Counter, Lowpass Sinc Filters, Bandpass and Highpass Sinc Filters, Interpolation using Sinc Filters, Decimation using Sinc Filters, Filtering Topologies: FIR Filters, Stability and Overflow, The Bilinear Transfer Function, The Canonic Form (or Standard Form) of a Digital Filter, General Canonic Form of a Recursive Filter, The Biquadratic Transfer Function, Comparing Biquads to Sinc-Shaped Filters. [8]

## **Module 4: Data converters**

Basics of Analog to digital converters (ADC), Basics of Digital to analog converters (DAC), Parameters of data converters, Quantization Noise, Quantization Noise Voltage Spectral Density, Signal-to-Noise Ratio (SNR), Clock Jitter, Improving SNR using Averaging, ADCs: Successive approximation ADCs, Dual slope ADCs, High-speed ADCs (e.g. flash ADC, pipeline ADC and related architectures), Hybrid ADC structures, High-resolution ADC (e.g. delta-sigma converters). DACs: Resistor string, R-2R Ladder networks, Current steering, Charge scaling DACs, Cyclic DAC, Pipelined DACs. [8]

## **Module 5: Phased lock loop**

Frequency Synthesizers and Phased lock loop: Simple PLL: Phase Detector, Basic PLL Topology, Dynamics of Simple PLL, Charge-Pump PLLs, Non-ideal Effect in PLLs: PFD/CP Nonidealities, Jitter in PLLs, Analog PLL, Digital PLL. Delay locked loops (DLL). [8]

### **TEXTBOOKS:**

1. CMOS mixed-signal circuit design by R. Jacob Baker, Wiley India, IEEE press, reprint 2008.
2. CMOS circuit design, layout and simulation by R. Jacob Baker, Revised second edition, IEEE press, 2008.
3. Design of analog CMOS integrated circuits by Behzad Razavi, McGraw-Hill, 2003.
4. Mixed-Signal Methodology Guide, by Jess Chen et al., First Edition, September 11, 2014

### **REFERENCE BOOKS:**

1. CMOS Integrated ADCs and DACs by Rudy V. dePlassche, Springer, Indian edition, 2005.

2. Electronic Filter Design Handbook by Arthur B. Williams, McGraw-Hill, 1981.
3. Design of analog filters by R. Schauman, Prentice-Hall 1990 (or newer additions).
4. An introduction to mixed-signal IC test and measurement by M. Burns et al., Oxford university press, first Indian edition, 2008.

## **COURSE OUTCOME (CO) ATTAINMENT ASSESSMENT TOOLS & EVALUATION PROCEDURE**

### **DIRECT ASSESSMENT**

<b>Assessment Tool</b>	<b>% Contribution during CO Assessment</b>
Quizzes (3)	3x10 = 30
Seminar	10
Teacher's Assessment	10
Semester End Examination	50

### **INDIRECT ASSESSMENT –**

1. Students' Feedback on Course Outcome

## **MAPPING BETWEEN COURSE OUTCOMES AND PROGRAM OUTCOMES**

<b>CO</b>	<b>PO1</b>	<b>PO2</b>	<b>PO3</b>	<b>PO4</b>	<b>PO5</b>	<b>PO6</b>
CO1	3	3	3	3	2	1
CO2	3	3	3	3	2	1
CO3	3	3	1	3	2	1
CO4	2	2	2	2	3	1
CO5	2	2	2	2	3	1

Correlation Levels 1, 2 or 3 as defined below:

1: Slight (Low) 2: Moderate (Medium) 3: Substantial (High)

**Gaps in the syllabus (to meet Industry/Profession requirements):** Hands-on-practical for fabrication of

mixed-signal VLSI circuit.

**POs met through Gaps in the Syllabus: PO6**

**Topics beyond syllabus/Advanced topics/Design:** Fabrication of mixed-signal circuit.

**POs met through Topics beyond syllabus/Advanced topics/Design: PO6**

**Course Delivery Methods**

<b>CD</b>	<b>Course Delivery methods</b>
CD1	Lecture by use of boards/LCD projectors/OHP projectors
CD2	Assignments
CD3	Seminar
CD4	Mini projects
CD5	Laboratory experiments/teaching aids
CD6	Self- learning such as use of NPTEL materials and internets
CD7	Simulation

**MAPPING BETWEEN COURSE OUTCOMES AND COURSE DELIVERY METHOD**

<b>Course Outcomes</b>	<b>Course Delivery Method</b>
CO1	CD1, CD2, CD3, CD6, CD7
CO2	CD1, CD2, CD3, CD6, CD7
CO3	CD1, CD2, CD3, CD6, CD7
CO4	CD1, CD2, CD3, CD6, CD7
CO5	CD1, CD2, CD3, CD6, CD7

**PROGRAMME CORE**

**COURSE INFORMATION SHEET**

**Course code: EC552**

**Course title: Microwave Integrated Circuit Lab**

**Pre-requisite(s): EC323 Microwave Theory &Techniques**

**Co- requisite(s):**

**Credits: L: 0 T: 0 P: 4 C: 2**

**Class schedule per week: 04**

**Class: M. Tech.Microwave Engg**

**Semester / Level: II/05**

**Branch: ECE**

**Name of Teacher:**

**Course Objectives:** This course enables the students



A.	To develop an understanding for design & analysis of LPF/ BPF and phase shifter
B.	To develop an understanding for design and analysis of coupled line coupler and branch line coupler.
C.	To develop an understanding for design and analysis of microstrip diplexer and power divider.
D.	To develop an understanding of active components based microstrip circuits such as LNA, oscillators and mixer
E.	To develop an understanding of combination of active and passive microwave circuits and their fabrications and measurement.

### **Course Outcomes**

After the completion of this course, students will be able to:

1	Demonstrate understanding of the design & analysis of LPF/ BPF and phase shifter.
2	Demonstrate understanding of the design and analysis of coupled line coupler and branch line coupler.
3	Demonstrate understanding of the design and analysis of microstrip diplexer and power divider.
4	Understand and analyse the active components based microstrip circuits such as LNA, oscillators and mixer
5	Demonstrate understanding of combination of active and passive microwave circuits and their fabrications and measurement.

### **Syllabus**

#### **LIST OF EXPERIMENTS:**

**(Experiments will be in 1-30 GHz)**

- 1) Design of microstrip low pass filter/ band pass filter.
- 2) Design of microwave band  $45^\circ$  and  $90^\circ$  Phase Shifters.
- 3) Design of coupled line coupler with arbitrary coupling coefficient
- 4) Design of 3-dB branch line coupler by using open stubs
- 5) Design of planar microstrip diplexer and triplexer using resonators.
- 6) Design of microstrip 3dB Wilkinson power divider
- 7) Design of high gain Low Noise Amplifier
- 8) Design of microstrip transistor Oscillator

- 9) Design of matched microwave mixer
- 10) Design of microstrip tuneable filter with PIN/ Varactor diode
- 11) Fabrication and Measurement of passive LPF/ BPF
- 12) Fabrication and Measurement of microstrip tuneable filter with PIN/ Varactor diode.

**TEXTBOOKS:**

1. Microwave Integrated circuit, K. C. Gupta, John Wiley, Newyork, 1974.
2. Microstrip lines and Slot lines, K.C. Gupta, R. Garg., I. Bahl, P. Bhartia, Artech House, Boston, 1996.

**REFERENCE BOOKS:**

1. RF Circuit Design, Reinhold Ludwig and Pavel Bretchko, Pearson, 2006.
2. Stripline-like Transmission lines for Microwave Integrated circuits, B. Bhat, S. K. Koul, Wiley Eastern Ltd., New Delhi.
2. Microwave Integrated Circuits, By Ivan Kneppo, J. Fabian, P. Bezousek

**Course Evaluation:** Progressive Evaluation and End-Sem. Evaluation

**Course Outcome (CO) Attainment Assessment Tools and Evaluation Procedure**

**Direct Assessment**

Assessment Tools	% Contribution during CO Assessment
Progressive Evaluation	60
End Semester Evaluation	40

Progressive Evaluation	% Distribution
Day to day performance & Lab files	30
Quizzes	10
Viva	20

End Semester Evaluation	% Distribution
Examination Experiment Performance	30
Quiz	10

**INDIRECT ASSESSMENT –**

## 1. Students' Feedback on Course Outcome

### **MAPPING BETWEEN COURSE OUTCOMES AND PROGRAM OUTCOMES**

CO	PO1	PO2	PO3	PO4	PO5	PO6
CO1	3	3	3	3	2	1
CO2	3	3	3	2	1	1
CO3	2	3	3	2	2	1
CO4	3	3	3	3	1	2
CO5	3	3	3	3	3	1

Correlation Levels 1, 2 or 3 as defined below:

1: Slight (Low) 2: Moderate (Medium) 3: Substantial (High)

**Gaps in the syllabus (to meet Industry/Profession requirements):** Hands on experience on solution of Real time Industrial Project and management

**POs met through Gaps in the Syllabus: PO5, PO6**

**Topics beyond syllabus/Advanced topics/Design:** through experiments involving design of circuits on advanced topics

**POs met through Topics beyond syllabus/Advanced topics/Design: PO4, PO5 & PO6**

### **Course Delivery Methods**

CD	Course Delivery methods
CD1	Lecture by use of boards/LCD projectors/OHP projectors
CD2	Assignments
CD3	Seminar
CD4	Mini projects
CD5	Laboratory experiments/teaching aids
CD6	Self- learning such as use of NPTEL materials and internets
CD7	Simulation

### **MAPPING BETWEEN COURSE OUTCOMES AND COURSE DELIVERY METHOD**

Course Outcomes	Course Delivery Method
CO1	CD1, CD3, CD7
CO2	CD1, CD3, CD7
CO3	CD1CD3, CD7
CO4	CD1, CD3, CD6, CD7
CO5	CD1, CD3, CD6, CD7

## COURSE INFORMATION SHEET

**Course code:** EC554

**Course title:** Computational Electromagnetics Lab.

**Pre-requisite(s):** MATLAB

**Co- requisite(s):** EC 553 Numerical technique in Electromagnetics

**Credits:** L: 0 T: 0 P: 4 C:2

**Class schedule per week:** 04

**Class:** M. Tech Microwave Engg

**Semester / Level:** II/05

**Branch:** ECE

**Name of Teacher:**

**Course Objectives:** This course enables the students:

A. .	Conceptualize the basics of numerical techniques to be used in EM.
B.	Recognize the nature of the problem under consideration.
C.	Develop codes for various numerical techniques.
D.	Apply developed code to EM problems.
E. .	Prepare reports, explain and present the results ethically.

### **Course Outcomes**

After the completion of this course, students will be:

1	Able to conceptualize the basics of numerical techniques to be used in EM.
2	Able to recognize the nature of the problem under consideration.
3	Able to develop codes for various numerical techniques.
4	Able to apply developed code to EM problems.
5	Able to prepare reports, explain and present the results ethically.

### **Syllabus**

#### **LIST OF EXPERIMENTS:**

##### **EXP 1**

Solve the differential equation

$$d^2y/dx^2+4x = 3, \text{ for } 0 \leq x \leq 1$$

Given  $y(0) = y(1) = 1$ , by finite difference method

**EXP 2**

Solve the one-dimensional Diffusion Equation. (Heat equation.)

$$\partial^2 \Phi / \partial x^2 = \partial \Phi / \partial t, \quad 0 \leq x \leq 1$$

having the boundary conditions

$$\Phi(0, t) = 0 = \Phi(1, t) = 0, \quad t > 0$$

and the initial condition

$$\Phi(x, 0) = 100$$

by finite difference method in time domain

**EXP 3**

Solve the one-dimensional wave eqn.

$$\Phi_{tt} = \Phi_{xx}, \quad 0 < x < 1, \quad t \geq 0$$

having the boundary conditions

$$\Phi(0, t) = 0 = \Phi(1, t), \quad t \geq 0$$

and the initial conditions

$$\Phi(x, 0) = \sin \pi x, \quad 0 < x < 1,$$

$$\Phi_t(x, 0) = 0, \quad 0 < x < 1$$

by finite difference method in time domain

**EXP 4**

Solve the two dimensional Laplace equation

$$\nabla^2 V = 0, \quad 0 \leq x, y \leq 1$$

$$\text{With } V(x, 1) = 45x(1-x), \quad V(x, 0) = 0 = V(0, y) = V(1, y)$$

by finite difference method

**EXP 5**

Find the characteristics impedance of a shielded double strip transmission line as shown in the figure.

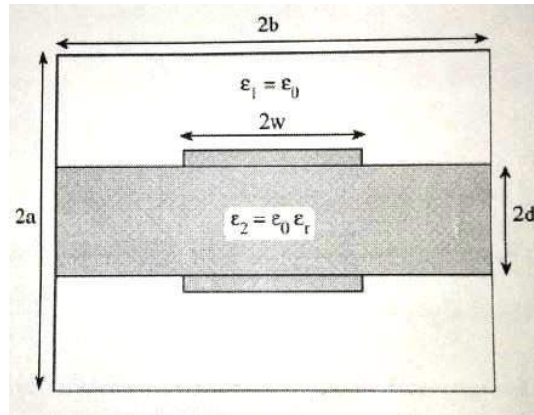

Where  $a = b = 2.5\text{cm}$ ,  $d = 0.5$ ,  $w = 1\text{cm}$ ,  $\epsilon_1 = \epsilon_0$ ,  $\epsilon_2 = 2.35\epsilon_0$

and the thickness of the strip is neglected. The potential difference applied between the outer metal shield and the inner strips is  $V_d = 100\text{mV}$ .

### EXP 6

Consider the scattering of  $\mathbf{a} + \mathbf{y}$  directed plane wave by a dielectric cylinder which is infinite along the Z-axis. The incident plane wave is Z-polarised and has amplitude  $1\text{ mV}$ . The cross section of the cylinder is circular of radius  $6\text{cm}$ . The geometry is shown in the figure. Find the variation of  $\mathbf{E}_z$  along the diameter shown by the solid line in time domain by Yee's FDTD method.

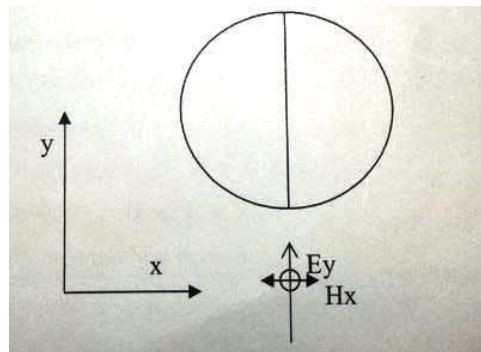

### EXP 7

A metal rod of length  $1\text{m}$  is placed along the X-axis. It is maintained at  $1\text{V}$  potential. Find the charge distribution induced over the rod by Method of Moments (MoM).

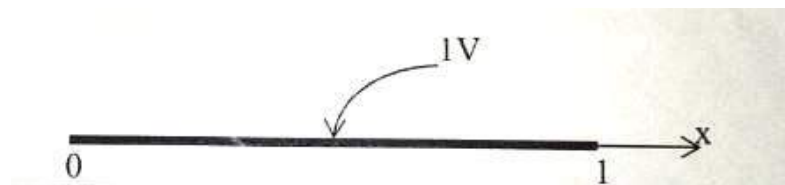

### EXP 8

A parallel plate capacitor with air as dielectric is given a potential difference  $1\text{V}$  across its plates. The area

of each square plate is  $A = 9\text{cm}^2$  and they are  $d = 0.5\text{cm}$  apart. Find its capacitance by method of moments (MoM). Compare your result with the formula  $C = \epsilon_0 A/d$ .

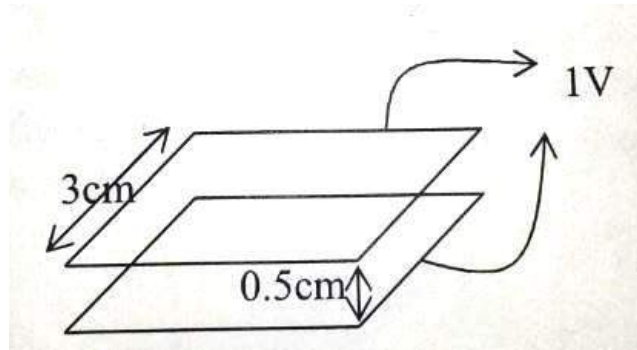

### EXP 9

A cylindrical dipole antenna of length  $0.01\lambda$  and radius  $0.001\lambda$  is fed at the centre by a signal generator of frequency 500 MHz and amplitude 1 mV as shown. Find the current distribution and the input impedance of the dipole by solving Electric Field Integral Equation (EFIE) by Method of Moments (MoM).

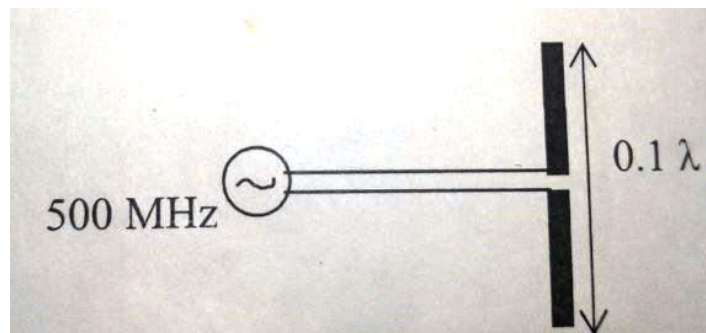

### EXP 10

A plane wave of frequency 1 GHz and amplitude 1 mV with electric field polarized along y-axis is incident upon a conducting square plate of dimension  $0.5\lambda$  along the  $-z$  direction. The plate is situated over the X-Y plane with origin at the centre. Find the current distribution induced over the plate by solving Electric Field Integral Equation (EFIE) by method of moments (MoM).

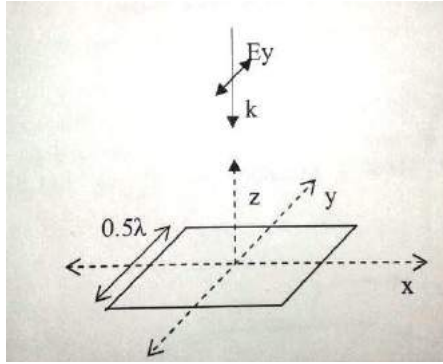

### EXP 11

Find the potential in the region R Shown in the figure by Finite Element Method (FEM). The coordinates of the four nodes and the potential at nodes 1 and 3 are specified.

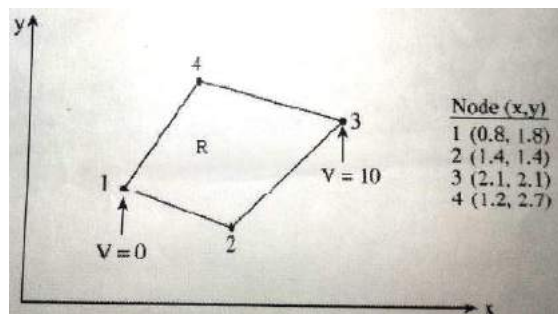

### EXP 12

Solve Laplace equation inside the region R as shown in the figure by Finite Element Method (FEM).



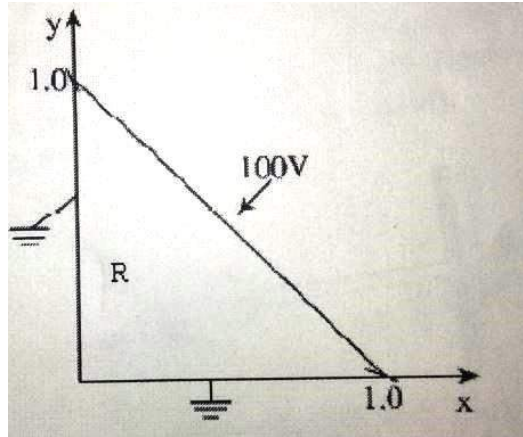

**TEXTBOOKS:**

Numerical Techniques in Electromagnetics by Mathew N. O. Sadiku (CRC Press)

**REFERENCE BOOKS:** Principles of Electromagnetics Mathew N. O. Sadiku, 3<sup>rd</sup> Ed.

**Course Evaluation:** Progressive Evaluation and End-Sem. Evaluation

**Course Outcome (CO) Attainment Assessment Tools and Evaluation Procedure**

**Direct Assessment**

Assessment Tools	% Contribution during CO Assessment
Progressive Evaluation	60
End Semester Evaluation	40

Progressive Evaluation	% Distribution
Day to day performance & Lab files	30
Quizzes	10
Viva	20

End Semester Evaluation	% Distribution
Examination Experiment Performance	30
Quiz	10

**INDIRECT ASSESSMENT –**

1. Students' Feedback on Course Outcome

**MAPPING BETWEEN COURSE OUTCOMES AND PROGRAM OUTCOMES**

Course Outcome CO	PO1	PO2	PO3	PO4	PO5	PO6
CO1	2	3	3	3	2	1
CO2	3	2	3	3	2	1

CO3	3	2	3	3	2	1
CO4	3	3	3	3	2	1
CO5	3	3	3	3	2	2

Correlation Levels 1, 2 or 3 as defined below:

1: Slight (Low) 2: Moderate (Medium) 3: Substantial (High)

**Gaps in the syllabus (to meet Industry/Profession requirements): Hands on experience on solution of real time industrial projects and management.**

**POs met through Gaps in the Syllabus: PO4, PO5 and PO6**

**Topics beyond syllabus/Advanced topics/Design: Through simulations based on advanced topics after completion of compulsory twelve experiments.**

**POs met through Topics beyond syllabus/Advanced topics/Design: PO4, PO5 & PO6**

#### **Course Delivery Methods**

<b>CD</b>	<b>Course Delivery methods</b>
CD1	Lecture by use of boards/LCD projectors/OHP projectors
CD2	Assignments
CD3	Seminar
CD4	Mini projects
CD5	Laboratory experiments/teaching aids
CD6	Self- learning such as use of NPTEL materials and internets
CD7	Simulation

#### **MAPPING BETWEEN COURSE OUTCOMES AND COURSE DELIVERY METHOD**

<b>Course Outcome CO</b>	<b>Course Delivery Method</b>
CO1	CD5, CD9
CO2	CD5, CD9
CO3	CD5, CD9
CO4	CD5 , CD9
CO5	CD5, CD9

### **PROGRAMME ELECTIVE – III**

### **COURSE INFORMATION SHEET**

**Course code:** EC517  
**Course title:** Satellite Based Wireless Communication  
**Pre-requisite(s):** EC357 Wireless Network, EC413 Satellite Communication  
**Co-requisite(s):**

**Credits:** L: 3 T: 0 P: 0 C:3  
**Class schedule per week:** 03  
**Class:** M. Tech. Microwave Engg.  
**Semester / Level:** III/06  
**Branch:** ECE  
**Name of Teacher:**

**Course Objectives:** This course enables the students:

A.	To acquire the concepts, fundamentals and importance of satellite communication, and impart knowledge on all the elements and aspects of satellite communication along with acquiring knowledge on various types of satellites used for several applications.
B.	To analyze, design and evaluate the satellite link for a specific frequency band
C.	To explain the propagation on satellite earth paths and its influence on link design.
D.	To develop the ability to acquire the knowledge various multiple access techniques in satellite communication.
E.	To develop the ability to appraise satellite networking and types of satellite networks.

**Course Outcomes:**

After the completion of this course, students will:

1	Demonstrate the concepts, fundamentals and importance of satellite communication, and impart knowledge on all the elements and aspects of satellite communication along with acquiring knowledge on various types of satellites used for several applications.
2	Have an ability to analyze, design and evaluate the satellite link for a specific frequency band.
3	Have an ability to explain the propagation on satellite earth paths and its influence on link design.
4	Acquire the knowledge of the various multiple access techniques in satellite communication.
5	Have an ability to demonstrate the concept of satellite networking and types of satellite networks.

## **Syllabus**

### **Module 1: Introduction to Satellite Communications and Orbital Aspects of Earth Satellites**

Origin, History, Current Technology State and Overview of Satellite System Engineering, Orbital Mechanics and Orbital Elements, Azimuth and Elevation, Coverage Angle and Slant Range, Placement of a Satellite in a Geostationary Orbit. [6]

### **Module 2: Satellite Link Design:**

Basic Radio Transmission Theory, System Noise Temperature and G/T Ratio, Uplink and Downlink Design, Interference Analysis, Carrier-to-Noise plus Interference Ratio, Interference to and from Adjacent Satellite Systems, Terrestrial Interference, Cross-polarization Interference, Intermodulation Interference, Design of Satellite Links for Specified Carrier-to-Noise plus Interference Ratio, Digital Satellite Link. [9]

### **Module 3: Propagation on Satellite-Earth Paths and Its Influence on Link Design:**

Absorptive Attenuation Noise by Atmospheric Gases, Rain Attenuation, Noise due to Rain, Rain Depolarization, Tropospheric Multipath and Scintillation Effects. [9]

### **Module 4: Multiple Access Techniques in Satellite Communications:**

Frequency Division Multiple Access, FDMA, SCPC, MCPC. Time Division Multiple Access, TDMA: random (ALOHA, S-ALOHA) and time synchronized access. Code Division Multiple Access, CDMA, Fixed and On-demand Assignment. [8]

### **Module 5: Satellite Networking and Types of Satellite Networks**

Advantages and Disadvantages of Multibeam Satellites, Interconnection by Transponder Hopping, Interconnection by On-board Switching, Interconnection by Beam Scanning, On-Board Processing, Intersatellite Links, Fixed Point Satellite Network, INTELSAT, Mobile Satellite Network, INMARSAT, Low Earth Orbit and Medium Earth Orbit Satellite Systems, Very Small Aperture Terminal (VSAT) Network, Direct Broadcast Satellite Systems, Global Positioning System. [9]

### **TEXTBOOKS:**

1. Digital Satellite Communications, 2/e, McGraw-Hill, 1990. Tri T. Ha
2. Satellite Communications, John Wiley and Sons, 2000. T. Pratt, C.W. Bostian
3. Satellite Communications Systems Engineering, Pearson Education, 2/e; 2003. W.L. Prichard, H.G. Snyderhoud and R.A. Nelson

## **COURSE OUTCOME (CO) ATTAINMENT ASSESSMENT TOOLS & EVALUATION PROCEDURE**

### **DIRECT ASSESSMENT**

<b>Assessment Tool</b>	<b>% Contribution during CO Assessment</b>
Quizzes (3)	3x10 = 30
Seminar	10
Teacher's Assessment	10
Semester End Examination	50

### **INDIRECT ASSESSMENT –**

1. Students' Feedback on Course Outcome

### **MAPPING BETWEEN COURSE OUTCOMES AND PROGRAM OUTCOMES**

<b>CO</b>	<b>PO1</b>	<b>PO2</b>	<b>PO3</b>	<b>PO4</b>	<b>PO5</b>	<b>PO6</b>
<b>CO1</b>	1	1	2	3	2	1
<b>CO2</b>	1	1	2	3	2	2
<b>CO3</b>	2	2	2	3	3	2
<b>CO4</b>	2	3	3	3	3	2
<b>CO5</b>	3	3	3	3	3	2

Correlation Levels 1, 2 or 3 as defined below:

1: Slight (Low) 2: Moderate (Medium) 3: Substantial (High)

#### **Gaps in the syllabus (to meet Industry/Profession requirements):**

Hands on experience on real-time industrial projects and management.

**POs met through Gaps in the Syllabus:** PO5 & PO6

#### **Topics beyond syllabus/Advanced topics/Design:**

OFDM based CSMA/CA, Multiple access schemes for Ad-hoc Network

**POs met through Topics beyond syllabus/Advanced topics/Design:** PO6

#### **Course Delivery Methods**

<b>CD</b>	<b>Course Delivery methods</b>
CD1	Lecture by use of boards/LCD projectors/OHP projectors
CD2	Assignments
CD3	Seminar

CD4	Mini projects
CD5	Laboratory experiments/teaching aids
CD6	Self- learning such as use of NPTEL materials and internets
CD7	Simulation

### MAPPING BETWEEN COURSE OUTCOMES AND COURSE DELIVERY METHOD

Mapping Between COs and Course Delivery (CD) methods	
Course Outcome	Course Delivery Method
CO1	CD1, CD2, CD6
CO2	CD1, CD2,CD3, CD6,
CO3	CD1, CD2, CD3, CD4, CD6
CO4	CD1, CD2, CD3, CD4, CD6,
CO5	CD1, CD2, CD3, CD4, CD6

### COURSE INFORMATION SHEET

**Course code: EC603**

**Course title: Millimetre Wave for Wireless Communication**

**Pre-requisite(s): EC323 Microwave Theory &Techniques**

**Co- requisite(s):**

**Credits: L:3 T:0 P:0 C:3**

**Class schedule per week: 03**

**Class: M. Tech. Microwave Engg.**

**Semester / Level: III/6**

**Branch: ECE**

**Name of Teacher:**

**Course Objectives :** This course enables the students

A.	To develop a brief theoretical foundation of Mm Wave technology, its potential use in Wireless Communications and its standards.
B.	To learn various channel effects in Mm Wave scenario and exposing the students to baseband techniques, antenna requirements, and Physical layer design and algorithms.
C.	To get exposed to the goals and challenges of new emerging applications of Mm Wave in Wireless Communications.
D.	To apply the acquired knowledge in the field of Mm Wave Wireless Communication in the future communication technologies.
E.	To review the literature related to Mm wave for Wireless Communication and to report it ethically.

### Course Outcomes

After the completion of this course, students will be:

1.	Be able to explain the fundamental concepts of Mm Wave Wireless Communication.
2.	Be able to analyze various channel effects in Mm Wave communication scenario and understand various design considerations.
3.	To get exposed to the goals and challenges of new emerging applications of Mm Wave in Wireless Communications.
4.	Be able to analyze challenges and various emerging applications of Mm Waves in Wireless Communications research field.
5.	Be able to review the literature related to Mm wave for Wireless Communication and to report it ethically.

### Syllabus

#### Module 1: Introduction

A Preview of MMWave Implementation Challenges, Emerging Applications of MmWave Communications MmWave Standardization.

**Module 2: Radio Wave Propagation for MmWave**

Large-Scale Propagation Channel Effects, Small-Scale Channel Effects, Spatial Characterization of Multipath and Beam Combining, Angle Spread and Multipath Angle of Arrival, Antenna Polarization, Outdoor and Indoor Channel Models. [8]

**Module 3: Antennas and Array for MmWave Applications**

Fundamentals of On-Chip and In-Package MmWave Antennas, Fundamentals of On-Chip and In-Package MmWave Antennas, In-Package Antennas, Antenna Topologies for MmWave Communications, Techniques to Improve Gain of On-Chip Antennas, Adaptive Antenna Arrays — Implementations for MmWave Communications, Characterization of On-Chip Antenna .performance.

[9]

**Module 4: Multi-Gbps Digital Baseband Circuits**

Review of Sampling and Conversion for ADCs and DACs, Device Mismatches: An Inhibitor to ADCs and DACs, Goals and Challenges in ADC Design, Encoders, Trends and Architectures for MmWave Wireless ADCs, Digital to Analog Converters. [9]

**Module 5: MmWave Physical Layer Design and Algorithms**

Practical Transceivers, High-Throughput PHYs, PHYs for Low Complexity, High Efficiency, Future PHY Considerations, Challenges when Networking mmWave Devices. [8]

**TEXTBOOKS:**

1. Theodore S. Rappaport, Robert W. Heath Jr., Robert C. Daniels, James N. Murdock, Millimeter Wave Wireless Communications, Prentice Hall, 2014.

**REFERENCE BOOK:**

1. Prakash Bhartia, and Inder Bahl, MmWave Engineering and Applications, Wiley-Interscience

**COURSE OUTCOME (CO) ATTAINMENT ASSESSMENT TOOLS & EVALUATION PROCEDURE****DIRECT ASSESSMENT**

Assessment Tool	% Contribution during CO Assessment
Quizzes (3)	3x10 = 30
Seminar	10
Teacher's Assessment	10



Semester End Examination	50
--------------------------	----

### INDIRECT ASSESSMENT –

1. Students' Feedback on Course Outcome

### MAPPING BETWEEN COURSE OUTCOMES AND PROGRAM OUTCOMES

CO	PO1	PO2	PO3	PO4	PO5	PO6
CO1	2	1	2	2	2	1
CO2	2	2	2	1	2	1
CO3	2	2	2	2	2	1
CO4	2	2	2	1	2	1
CO5	1	3	2	2	2	1

Correlation Levels 1, 2 or 3 as defined below:

1: Slight (Low) 2: Moderate (Medium) 3: Substantial (High)

**Gaps in the syllabus (to meet Industry/Profession requirements):** Hands on experience on real time industrial projects and management.

POs met through Gaps in the Syllabus: **PO5 & PO6**

#### **Topics beyond syllabus/Advanced topics/Design:**

Applications of Millimeter wave in 5G wireless communication.

POs met through Topics beyond syllabus/Advanced topics/Design: **PO5 & PO6**

#### **Course Delivery Methods**

CD	Course Delivery methods
CD1	Lecture by use of boards/LCD projectors
CD2	Tutorials/Assignments
CD3	Seminars
CD4	Industrial visits/in-plant training
CD5	Self- learning such as use of NPTEL materials and internets
CD6	Simulation

### MAPPING BETWEEN COURSE OUTCOMES AND COURSE DELIVERY METHOD

Mapping Between COs and Course Delivery (CD) methods
--

Course Outcome	Course Delivery methods
CO1	CD1,CD6
CO2	CD1, CD6,CD7
CO3	CD1, CD2, CD3,CD6,CD7
CO4	CD1, CD3,CD6,CD7
CO5	CD1,CD2,CD3,CD4,CD7

## COURSE INFORMATION SHEET

**Course code:** EC604  
**Course title:** Microwave measurement and Material Characterization  
**Pre-requisite(s):** E323 Microwave Theory & Techniques, EC257 Electromagnetic Fields and Waves

**Co- requisite(s):**

**Credits:** L:3 T:0 P:0 C:3

**Class schedule per week:** 3

**Class:** M. Tech. Microwave Engg.

**Semester / Level:** III/06

**Branch:** ECE

Name of Teacher:

### Course Objectives

This course enables the students:

A.	To understand the general properties of electromagnetic materials and their underlying physics at microwave frequency
B.	To provide the principles of various microwave methods for material characterization.

### Course Outcomes

After the completion of this course, students will be able:

1.	To discuss the parameters describing the electromagnetic properties of materials at microscopic and macroscopic scales.
2.	To categorize electromagnetic materials.

3.	To identify suitable method for material characterization.
4.	To apply various methods to characterize materials at microwave frequencies.
5.	Acquire the capability to modify basic material characterization techniques.

## **Syllabus**

### **Module 1: Electromagnetic Properties of Materials:**

Materials Research and Engineering at Microwave Frequencies, Physics for Electromagnetic Materials, General Properties of Electromagnetic Materials. [6]

### **Module 2: Reflection and Transmission/Reflection Methods**

Introduction, Coaxial-Line Reflection Method, Free-Space Reflection Method, Measurement of Both Permittivity and Permeability Using Reflection Methods. Transmission/Reflection: Working Principle of Transmission/Reflection Methods, NRW algorithm Coaxial Air-Line Method, Hollow Metallic Waveguide Method, Free-Space Method. [9]

### **Module 3: Resonator Methods**

Introduction, Dielectric Resonator Methods, Coaxial Surface-Wave Resonator Methods, Split-Resonator Method, Dielectric Resonator Methods. [9]

### **Module 4: Resonant Perturbation Methods**

Basic Theory, Cavity-Perturbation Method, Dielectric Resonator Perturbation Method, Measurement of Surface Impedance. [8]

### **Module -5: Planar-Circuit Methods**

Introduction, Stripline Methods, Microstrip Methods, Coplanar-Line Methods. [8]

## **TEXTBOOK:**

1. Microwave Electronics: Measurement and Materials Characterization, L. F. Chen, C. K. Ong, C. P. Neo, V. V. Varadan, Vijay K. Varadan, John Wiley , ISBN: 978-0-470-84492-2

## **COURSE OUTCOME (CO) ATTAINMENT ASSESSMENT TOOLS & EVALUATION PROCEDURE**

### **DIRECT ASSESSMENT**

<b>Assessment Tool</b>	<b>% Contribution during CO Assessment</b>
Quizzes (3)	3x10 = 30

Seminar	10
Teacher's Assessment	10
Semester End Examination	50

### INDIRECT ASSESSMENT –

1. Students' Feedback on Course Outcome

### MAPPING BETWEEN COURSE OUTCOMES AND PROGRAM OUTCOMES

CO	PO1	PO2	PO3	PO4	PO5	PO6
CO1	2	1	3	3	3	2
CO2	2	1	3	3	2	2
CO3	1	1	3	3	3	2
CO4	3	2	3	3	3	3
CO5	3	2	3	3	3	3

Correlation Levels 1, 2 or 3 as defined below:

1: Slight (Low) 2: Moderate (Medium) 3: Substantial (High)

**Gaps in the syllabus (to meet Industry/Profession requirements):** Hands on experience on real-time industrial projects and management

**POs met through Gaps in the Syllabus:** Nil

**Topics beyond syllabus/Advanced topics/Design:** Measurement of permittivity and permeability tensor.

**POs met through Topics beyond syllabus/Advanced topics/Design:** NA

### Course Delivery Methods

CD	Course Delivery methods
CD1	Lecture by use of boards/LCD projectors/OHP projectors
CD2	Assignments
CD3	Seminar
CD4	Mini projects
CD5	Laboratory experiments/teaching aids
CD6	Self- learning such as use of NPTEL materials and internets
CD7	Simulation

## MAPPING BETWEEN OUTCOMES AND COURSE DELIVERY METHODS

Mapping Between COs and Course Delivery (CD) methods	
Course Outcome	Course Delivery Method
CO1	CD1, CD2, CD6
CO2	CD1, CD2, CD6
CO3	CD1, CD2, CD6
CO4	CD1, CD2, CD3, CD4, CD6, CD7
CO5	CD1, CD2, CD3, CD4, CD6, CD7

### THIRD SEMESTER

#### PROGRAMME CORE

EC600 Thesis (Part I)

Credit:8

### OPEN ELECTIVE-1

#### COURSE INFORMATION SHEET

Course code: EC547

Course title: Fundamentals of MEMS

Pre-requisite(s): Any Branch in UG Engg/Applied Science

Co-requisite(s):

Credits: L: 3 T: 0 P: 0 C: 3

Class schedule per week: 03

Class: M. Tech.

Semester / Level: I/05

Branch: ECE

Name of Teacher:

Course Objectives: This course enables the students

A.	Introduction to MEMS and micro fabrication to develop an ability, enthusiasm critical thinking in microengineering process, materials and design issues
B.	To study the essential material properties and understanding of microscale physics for use in designing MEMS devices
C.	To study various sensing and transduction technique to develop an ability and understanding of microscale physics for use in designing MEMS devices
D.	To develop an inclination towards electronics system design and manufacturing
E.	To develop the fundamental concepts of MEMS technology & their applications in different areas

Course Outcomes:

After the completion of this course, students will be:

1.	Demonstrate knowledge on fundamental principles and concepts of MEMS Technology
2.	Have an ability to analyse various techniques for building micro-devices in silicon, polymer, metal and other materials
3.	Correlate micro-systems technology for technical feasibility as well as practicality using modern tools and relevant simulation software to perform design and analysis.
4.	Have an ability to compare physical, chemical, biological, and engineering principles involved in the design and operation of current and future micro-devices
5.	Be fluent with the design, simulation and development MEMS Devices.

## **Syllabus**

### **Module-1: Introduction**

The History of MEMS Development, Intrinsic characteristics of MEMS, MEMS sensors and actuators, Sensor noise and Design complexity. Introduction to Microfabrication Essential overview of frequently used micro fabrication processes. Thin film deposition techniques, wafer bonding Silicon Based MEMS processes, MEMS Materials. [8]

### **Module-2: Essential Electrical and Mechanical Concepts**

Crystal planes & orientations, General Scalar relation between Tensile stress and strain, Mechanical properties of silicon and related thin films, Flexural Beam bending Analysis, Dynamic System, Resonant Frequency and quality factor, Electromechanical and Direct Analogy in Electrical and Mechanical domain. [8]

### **Module -3: Sensing and Actuation schemes**

Electrostatic Sensors and Actuators, Thermal sensors and actuators, Piezoresistive Sensors, Piezoelectric Sensors and Actuators, Magnetic Actuators. Comparison of Major Sensing and Actuation Methods and their Applications. [8]

### **Module 4: MEMS Packaging and Integration**

Role of MEMS packages. Mechanical support Electrical interface Protection from the environment Thermal considerations Types of MEMS packages Metal packages Ceramic packages Plastic packages 368, Multilayer packages Embedded overlay Wafer-level packaging, Microshielding and self-packaging, Flip-chip assembly Multichip module packaging, Wafer bonding. [8]

## Module 5: Case studies for selected MEMS Products

Blood Pressure Sensor, Microphone, Accelerometer, Performance and Accuracy.

[8]

### TEXTBOOKS:

1. Foundations of MEMS by Chang Liu, Second Edition, Pearson, ISBN 978-81-317-64756.
2. RF MEMS and Their Applications, Vijay K. Varadan, K.J. Vinoy and K.A. Jose, Wiley India Pvt Ltd., Wiley India Edition, ISBN 978-81-265-2991-9.

### REFERENCE BOOKS:

1. Marc Madou, Fundamentals of Microfabrication by, CRC Press, 1997. Gregory Kovacs, Micromachined Transducers Sourcebook WCB McGraw-Hill, Boston, 1998.
2. M.-H. Bao, Micromechanical Transducers: Pressure sensors, accelerometers, and gyroscopes by Elsevier, New York, 2000.
3. RF MEMS and Their Applications, Vijay K. Varadan K.J. Vinoy K.A. Jose Pennsylvania State University, USA, John Wiley & Sons Ltd -2003.

## COURSE OUTCOME (CO) ATTAINMENT ASSESSMENT TOOLS & EVALUATION PROCEDURE

### DIRECT ASSESSMENT

Assessment Tool	% Contribution during CO Assessment
Quizzes (3)	3x10 = 30
Seminar	10
Teacher's Assessment	10
Semester End Examination	50

### INDIRECT ASSESSMENT –

1. Students' Feedback on Course Outcome

### INDIRECT ASSESSMENT –

1. Students' Feedback on Course Outcome

## MAPPING BETWEEN COURSE OUTCOMES AND PROGRAM OUTCOMES

CO	PO1	PO2	PO3	PO4	PO5	PO6
CO1	3	2	2	3	2	1
CO2	3	3	3	3	2	1
CO3	3	3	1	3	2	1

<b>CO4</b>	2	2	2	2	3	2
<b>CO5</b>	2	2	2	2	3	2

Correlation Levels 1, 2 or 3 as defined below:

1: Slight (Low) 2: Moderate (Medium) 3: Substantial (High)

**Gaps in the syllabus (to meet Industry/Profession requirements):** Design of real-time industrial /Research projects.

**POs met through Gaps in the Syllabus:** PO3 & PO6

**Topics beyond syllabus/Advanced topics/Design:** Design optimization for industrial projects, Micro-fabrication techniques and MEMS devices.

**POs met through Topics beyond syllabus/Advanced topics/Design:** PO3 & PO4

#### Course Delivery Methods

<b>CD</b>	<b>Course Delivery methods</b>
CD1	Lecture by use of boards/LCD projectors/OHP projectors
CD2	Assignments
CD3	Laboratory experiments/Teaching aids/Seminars
CD4	Mini Projects
CD5	Industrial visits/in-plant training
CD6	Self- learning such as use of NPTEL materials and internets
CD7	Simulation

#### MAPPING BETWEEN COURSE OUTCOMES AND COURSE DELIVERY METHOD

<b>Course Outcomes</b>	<b>Course Delivery Method</b>
<b>Course Outcomes</b>	<b>Course Delivery Method</b>
CO1	CD1, CD2, CD3, CD6
CO2	CD1, CD2, CD3, CD6
CO3	CD1, CD2, CD3, CD4, CD6,
CO4	CD1, CD2, CD3, CD6, CD7
CO5	CD1, CD2, CD3, CD4, CD6, CD7



# OPEN ELECTIVE-II

## COURSE INFORMATION SHEET

**Course code:** EC597

**Course title:** Fundamentals of Microwaves.

**Pre-requisites:** Any Branch in UG Engg/Applied Science

**Credits:** L: 3 T: 0 P: 0 C:3

**Class schedule per week:** 03

**Class:** M.tech. Microwave Engg.

**Level:**II/ 05

**Branch:** ECE

**Name of Teacher:**

**Course Objectives :** This course enables the students to

A.	Understand important and unique engineering issues at microwave wave frequencies basic concepts of microwave systems.
B.	Understand the concept of microwave network theory and the use of scattering matrix,
C.	Design, analyze and solve problems related to microwave waveguide. transmission lines.
D.	Analyze, test and use various passive microwave components for different applications.
E.	Design and implement the microwave layouts

### Course Outcomes

After the completion of this course, students will be able to:

1	To understand about the microwave frequencies and the waveguides that are used in communication.
2.	Understand and Analyze various parameters and characteristics of the various waveguide components.
3.	Apply Smith chart use for solution of transmission line problems and impedance matching
4	Analyze the difference between the conventional tubes and the microwave tubes for the transmission of the EM waves.
5	Acquire knowledge about the measurements to be done at microwaves.

### Syllabus

#### Module 1: Introduction to microwaves

Microwave frequencies, advantages of microwaves, Special features and general applications of microwaves.

[6]

## Module 2: Microwave transmission lines and wave guides

Mathematical model of Microwave Transmission Concept of Mode, Characteristics of TEM, TE and TM Modes, Losses associated with microwave transmission, Concept of Impedance in Microwave Transmission line equations & solutions, reflection and transmission coefficient, standing wave and standing wave ratio, line impedance and admittance, impedance matching, Rectangular and circular waveguides-theory and analysis. [10]

## Module 3: Microwave Network Analysis

Network parameters for microwave Circuits, Scattering Parameters. Microwave Passive components: Directional Coupler, Power Divider, Magic Tee, Wave-guide Corners, Bends, Twists, Attenuator, Circulator, Isolator and Resonator.

[9]

## Module 4: Microwave sources

Tubes and circuits: Limitations of conventional tubes at UHF & Microwave, Klystrons, multicavity klystron, Reflex klystron, travelling wave tube, Magnetron. Solid state devices: Tunnel diode, Varactor diodes, PIN diodes, Gunn diodes, IMPATT and TRAPATT diodes.

[9]

## Module 5: Microwave Measurements Power

Frequency and impedance measurement at microwave frequency, Network Analyzer and measurement of scattering parameters, spectrum Analyzer and measurement of spectrum of a microwave signal.

[6]

### TEXTBOOKS:

1. Samuel Y.Liao, "Micro wave Devices and Circuits", 3 rd edition, Pearson education
2. R.E.Collin, "Foundations for microwave Engineering", 2 nd edition, Tata Mc Graw Hill,1992.
3. David Pozar, *Microwave Engineering*, 3<sup>rd</sup> edition, (Wiley, 2005).

### REFERENCE BOOKS:

- 1.Microwave Technology, Dennis Roddy , PHI

## COURSE OUTCOME (CO) ATTAINMENT ASSESSMENT TOOLS & EVALUATION PROCEDURE

### DIRECT ASSESSMENT

Assessment Tool	% Contribution during CO Assessment
Quizzes (3)	3x10 = 30

Seminar	10
Teacher's Assessment	10
Semester End Examination	50

### INDIRECT ASSESSMENT –

1. Students' Feedback on Course Outcome

### **MAPPING BETWEEN COURSE OUTCOMES AND PROGRAM OUTCOMES**

CO	PO1	PO2	PO3	PO4	PO5	PO6
CO1	3	2	1	3	1	2
CO2	3	2	1	3	2	1
CO3	3	1	2	3	2	1
CO4	3	2	2	3	2	2
CO5	3	3	3	3	3	3

Correlation Levels 1, 2 or 3 as defined below:

1: Slight (Low) 2: Moderate (Medium) 3: Substantial (High)

#### **Gaps in the syllabus (to meet Industry/Profession requirements):**

Hands on experience on real time industrial project and management

**POs met through Gaps in the Syllabus: PO4 & PO5.**

#### **Topics beyond syllabus/Advanced topics/Design:**

Microwave amplifier Mixer, mm wave trans receiver, High power broadband solid state isolators

POs met through Topics beyond syllabus/Advanced topics/Design: **PO4, PO5&O6**

#### **Course Delivery Methods**

CD	Course Delivery methods
CD1	Lecture by use of boards/LCD projectors/OHP projectors
CD2	Assignments
CD3	Seminar
CD4	Mini projects
CD5	Laboratory experiments/teaching aids

CD6	Self- learning such as use of NPTEL materials and internets
CD7	Simulation

**MAPPING BETWEEN COURSE OUTCOMES AND COURSE DELIVERY METHOD**

<b>Course Outcomes</b>	<b>Course Delivery Method</b>
CO1	CD1,CD6
CO2	CD1, CD2, CD3,CD7
CO3	CD1, CD2, CD3,CD6,CD7
CO4	CD1, CD3,CD6,CD7
CO5	CD1,CD2,CD3,CD4,CD5,CD7

**FOURTH SEMESTER**

**PROGRAMME CORE**

**EC650 Thesis (Part II)**

**Credit: 16**